

SEDM-2D

Multi compartment smoke control damper

Technical Documentation

Installation, Commissioning, Operation, Maintenance and Service Manual

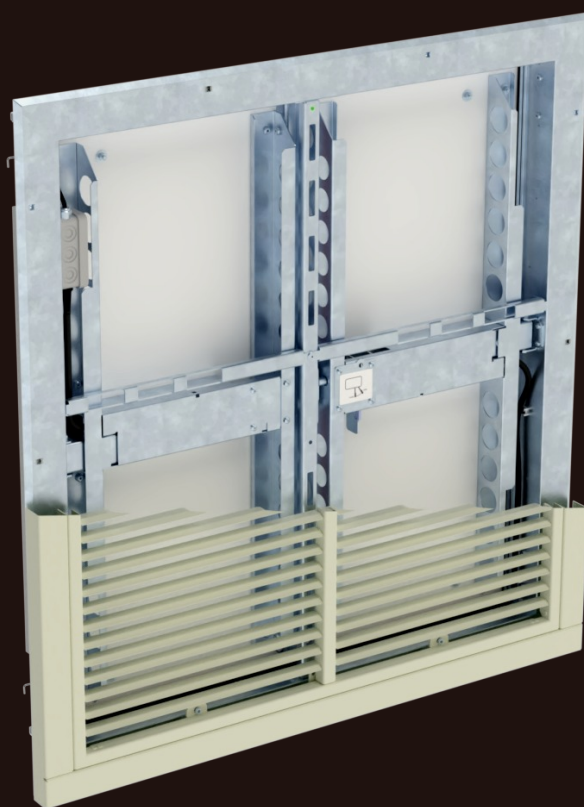

These technical specifications state a type range of manufactured sizes and models of Multi compartment smoke control damper SEDM-2D. It is valid for production, designing, ordering, delivery, maintenance and operation.

CONTENT

- I. GENERAL.....3
 - Description.....3
- II. DESIGN.....5
 - Hand-operated designs.....6
 - Grilles designs.....7
 - Electric parameters, wiring diagram.....10
- III. DAMPER CONTROL.....12
- IV. DIMENSIONS.....14
 - Technical parameters.....15
- V. INSTALLATION.....18
 - Placement and Installation.....18
 - Statement of installations.....19
 - Installation procedure.....20
 - Cable connection.....21
 - Shock absorber.....22
 - Installation frame.....22
 - Installation - shaft from concrete or aerated concrete.....25
 - Installation - shaft from fire-resistant panels.....27
- VI. TECHNICAL DATA.....29
 - Pressure loss.....29
- VII. MATERIAL, FINISHING.....30
- VIII. TRANSPORTATION, STORAGE AND WARRANTY.....30
 - Logistic terms.....30
 - Warranty.....30
- IX. ASSEMBLY, ATTENDANCE AND MAINTENANCE.....31
 - Commissioning and revisions.....31
- X. ORDERING INFORMATIONS.....32
 - Ordering key.....32
 - Accessories.....33
 - Spare parts.....33
 - Data label.....34

I. GENERAL

Description

Smoke control dampers SEDM-2D (hereinafter named also simply as „the dampers“) are intended to be used in multi compartment smoke control systems in vertical duct (shaft) installations.

In normal situation, the dampers remain closed (stand-by position). Upon an activation signal emitted either in the event of a fire, or during a functional test, the dampers of given compartments open in order to allow smoke and heat from the fire to be extracted outside the building. SEDM-2D dampers open to the inside of the duct. The dampers opened during functional testing may be put back to the stand-by (closed) position by hand.

The dampers consist of a two calcium-silicate blade reinforced by steel crossbeams hanged on spring-equipped hinges, combined calcium-silicate and galvanized steel body, a cold seal (silicon gasket) and a carbon based thermo-expanded hot seal, electrically activated restraint mechanism equipped by a permanent magnet with an electric coil, optional with end switches, and a metallic grille.

The dampers may be installed to the shaft directly using fire-resistant mastic, or using an optional installation frame.



SEDM-2D dampers are characterized by

- Zero power consumption in stand-by position
- Instant opening and fast closing
- Small built-in dimensions
- Light design of high fire and pressure resistance
- Large effective area
- Room protected from moving parts
- Wide range of damper dimensions
- Wide range of colours available
- Easy installation also into thin shaftwall materials
- Availability of spare parts

Specifications

- Dimensions width B x height H
 - from 350x300 mm up to 1105 x 1105 mm by 5 mm
- Total depth of 90 mm (built-in depth 83 mm) without grille
- Grilles of 77% to 95% effective cross section available
- Opening and securing within 5 seconds
- Activation signal – pulse of length of 1 s min 24 V DC, or 48 V DC
- Degree of protection IP42 (electric part)
- In acc. with Regulation (EU) 305/2011 (CPR), EU Directive (EU) 2014/30/EU (EMC), Directive (EU) 2011/65/EU (RoHS)
- CE certification according to EN 12101-8
- Tested according to EN 1366-10
- Classified according to 13501-4
- Fire resistance cf. tab. bellow
- Pressure class 3 (underpressure 1500 Pa / overpressure 500 Pa)
- Closed blade tightness class 3 according to EN 1751
- Certificate of Constancy of Performance No. 1391-CPR-XXXX/XXXX
- Declaration of Performance No. PM/SEDM-2D/01/XX/X
- EU Declaration of Conformity No. PM/SEDM-2D/03/XX/X
- Certificate EMC SZÚ N. EMC-B-00933-23 (EMC), test report SZÚ No. 31-10777/1/IP (IP42)
- Efectis France Test report on fitness for use of mechanisms No. EFR-25-000237
- In accordance with NF 61.937-1 and NF 61.937-10

Classification of Dampers

Vertical duct (shaft) construction	Classification**
Concrete or aerated concrete of thickness min. 70 mm, with or without installation frame	EI 120 (v _{ed}) S1500[V]C ₃₀₀ (N)AAmulti
Selected light smoke extraction duct panels of given thickness*, with or without installation frame	EI 120 (v _{ed}) S1500[V]C ₃₀₀ (N)AAmulti, or EI 90 (v _{ed}) S1500[V]C ₃₀₀ (N)AAmulti, or EI 60 (v _{ed}) S1500[V]C ₃₀₀ (N)AAmulti, depending on panel material and thickness*.

* → see page 19 for the variety of shaft panel materials and thicknesses and installation details with corresponding damper fire resistance class.

** The classification applies only to the damper equipped with a grille.

Operating conditions

Both declared performance and faultless operation are ensured under the following conditions:

- The damper shall be equipped with a protection grille
- Maximum vacuum up to 1500 Pa or overpressure up to 500 Pa
- Rearming shall be carried out without air flow and without air pressure
- The dampers are suitable for vertical installation only
- Range of activation voltage shall be respected; dimensioning of voltage sources and of connecting cables shall fit the electrical parameters of the damper
- Connecting cables shall not physically impede free movement of moving parts and sub-assemblies
- Damper shall be always kept closed with the exception of short periods of installation, commissioning and functional tests
- Dampers are designed for macroclimatic areas with mild climate according to EN IEC 60 721-3-3 ed.2., class 3K22. (Environment 3K22 is typically protected place with regulated temperature) and with a temperature range of -25°C to 50°C

II. DESIGN

Connecting cables shall be guided from a pre-punched hole in one of the corners of the damper frame to the junction box using delivered cable clips. The junction box contains a universal 10-position screw terminal. Damper supply voltage and terminal block positions are printed inside the junction box. Depending on the damper design configuration and connecting cables available, some terminal positions may stay void. Additional junction box with 6-position screw terminal is present for bipolar end-switch module.

The damper is equipped with a restraint mechanism keeping the damper closed. The restraint mechanism includes a permanent magnet combined with an electric coil with

magnetic poles opposite to those of the permanent magnet. In case of the activation of the damper, the coil magnetic field compensates the magnetic field of the magnet and thus, the restraint mechanism lets the damper open. The activation signal represents a simple switching the voltage ON. The damper may be equipped with position end-switch module with end-switches indicating the damper blade position open or closed. The damper is manufactured in hand-operated rearming design. Rearming means getting the damper blades from the position open (security) to the position closed (stand-by).

SEDM-2D hand-operated design



Hand-operated designs

Design .24C0H

- Hand-operated rearming design with a magnet voltage of 24 V DC without end switches. This design is not in accordance with NF 61.937-1, and not in accordance with NF 61.937-10.

Design .24C2H

- Hand-operated rearming design with a magnet voltage of 24 V DC and with two end switches signaling of the damper blade position "CLOSED" (STAND-BY) and "OPEN" (SECURITY).

Design .24C4H

- Hand-operated rearming design with a magnet voltage of 24 V DC and with two pairs of end switches signaling of the damper blade position "CLOSED" (STAND-BY) and "OPEN" (SECURITY).

Design .48C0H

- Hand-operated rearming design with a magnet voltage of 48 V DC without end switches. This design is not in accordance with NF 61.937-1, and not in accordance with NF 61.937-10.

Design .48C2H

- Hand-operated rearming design with a magnet voltage of 48 V DC and with two end switches signaling of the damper blade position "CLOSED" (STAND-BY) and "OPEN" (SECURITY).

Design .48C4H

- Hand-operated rearming design with a magnet voltage of 48 V DC and with two pairs of end switches signaling of the damper blade position "CLOSED" (STAND-BY) and "OPEN" (SECURITY).

End switch module

- End switch module can be equipped with 2 end switches or with 2 pairs of end switches (both positions 2x) CLOSED, OPEN

End switch G905-200S02D1

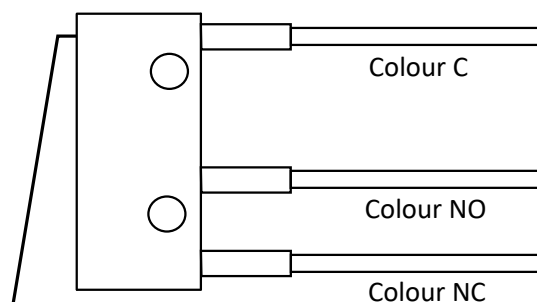

- Wiring diagram of end switches → see page 11

End-switches

Type; configuration	G905; (C-NO-NC)
Voltage	≤ 60 V DC
Switchable DC current	> 0.5 A
Contact resistance	< 0.1 Ohm
Insulation voltage open contact	> 500 V
Cut-off power (DC)	> 10 W
Longevity – cycles	> 1000
Microswitch AC rating	230 V AC / 5 A
Microswitch degree of protection	IP67
Compliance	NF 61.937-1, NF 61.937-10

Grilles designs

- The damper shall be equipped with a protection grille G1, G2, G3, G4, G5, G6 or GX.
- Grille G1 is not powder painted as standard. Can be powder painted, if specified in the ordering key.
- Grilles G2, G3, G4, G5, G6 are powder painted. If no colour is specified in the ordering key, the colour will be RAL 9010.
- GX grilles are other grilles that must be additionally reviewed and approved by a third-party. This must be discussed with Mandík company in advance. The review process is based on documentation exchange only.
- Allen screws M5 and washers are used for G1, G2, G4, G5 and G6 grilles.
- Allen screws M4, hexagon head screws M5 and washers are used for G3 grilles.
- Fasteners are delivered with the grille.
- Dimensions for mounting of grilles → see page 14

Grille G1

- Simple, the lightest grille made of a punched 2 mm Al sheet, 77% effective area.

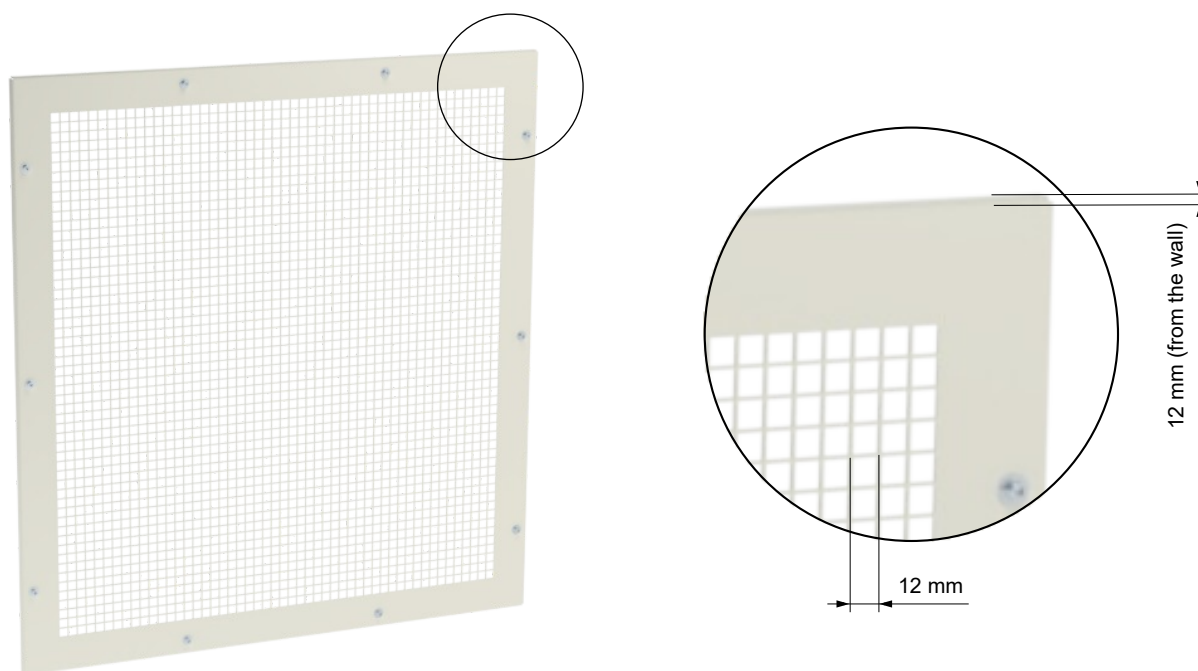

Grille G2

- Design grille with aerodynamic profile louvers made of Al alloy, 77% effective area.

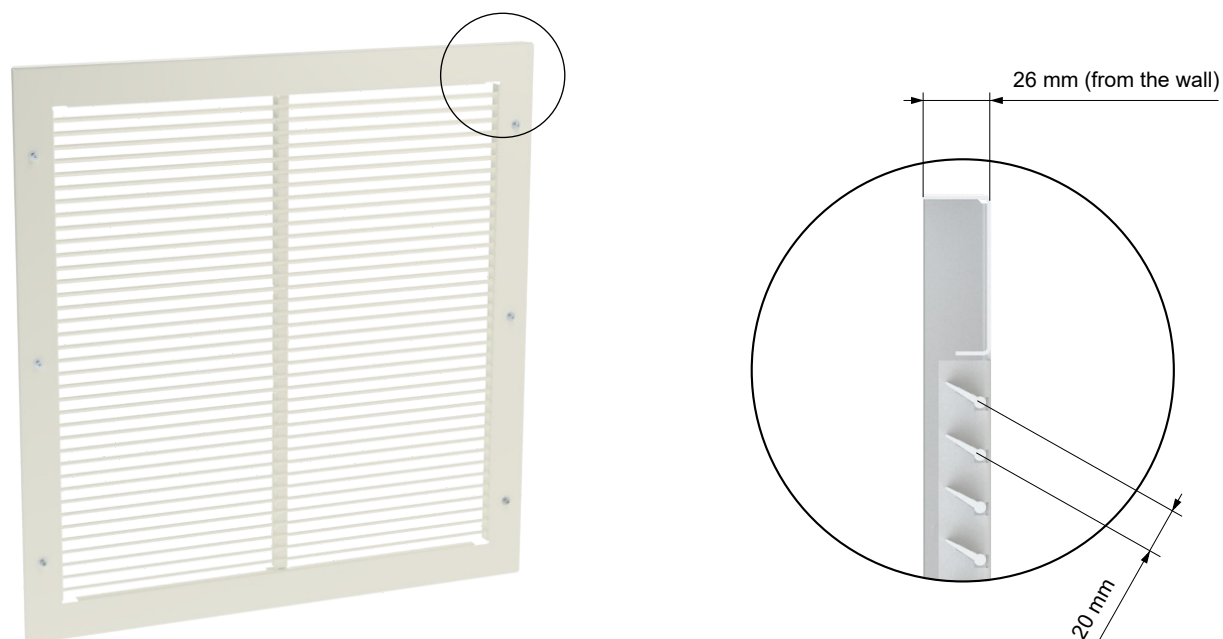

Grille G3

- Design grille with thin louvers made of Al sheet, no visible bolts, easy to open and close, 95% effective area.
- The movable central part of the grille can be easily removed from the grille frame completely, and then put back easily.

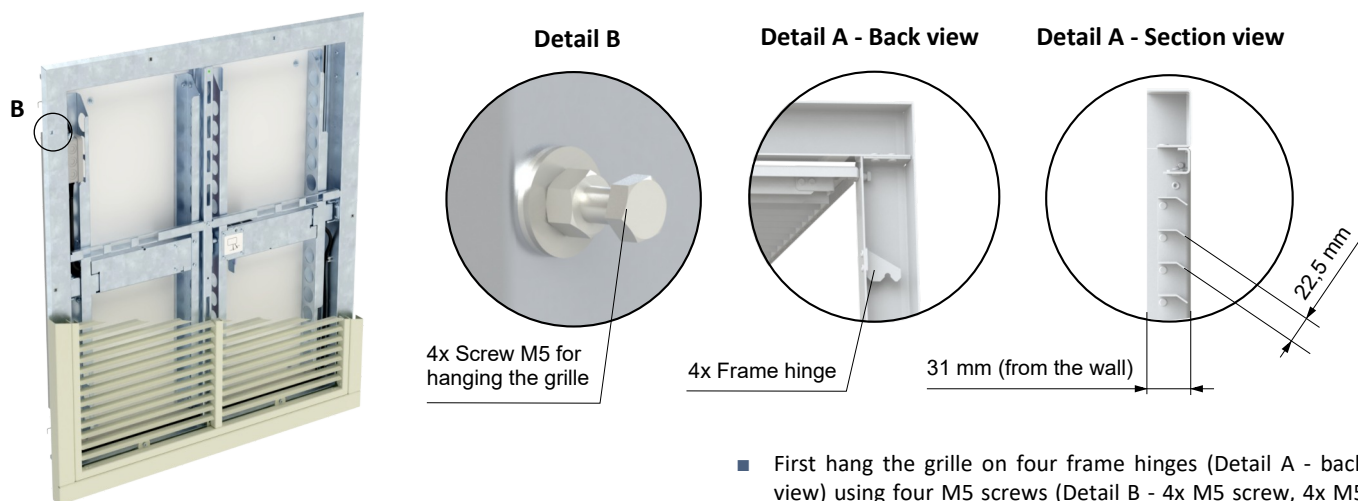
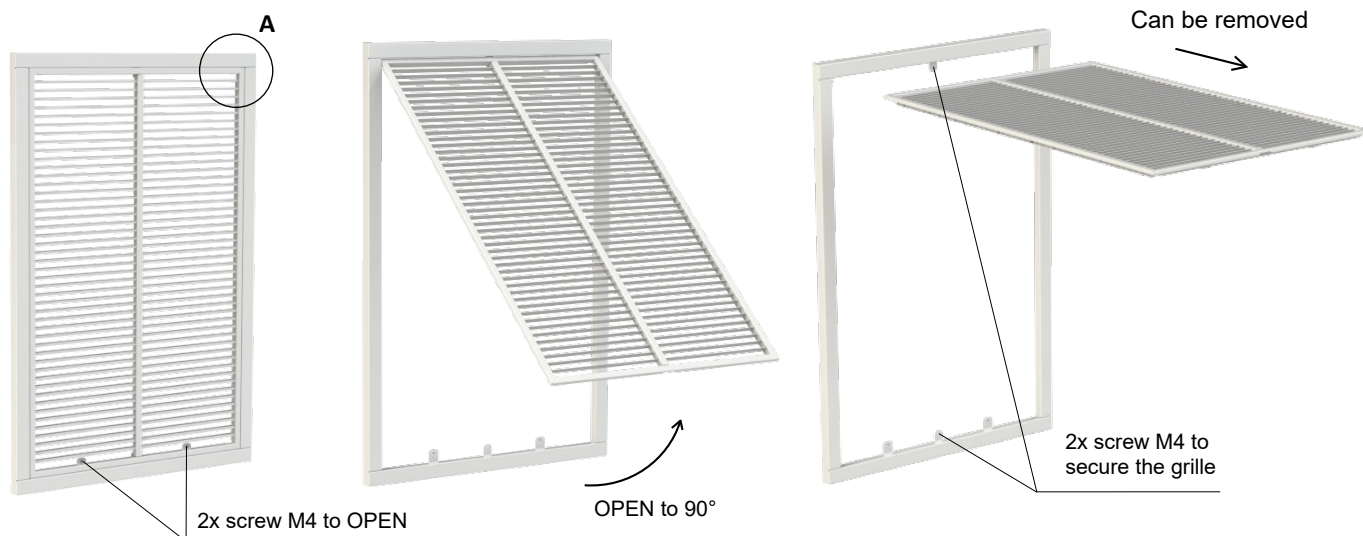

Grille G4

- Design grille made of steel (punched and drawn), 78% effective area.

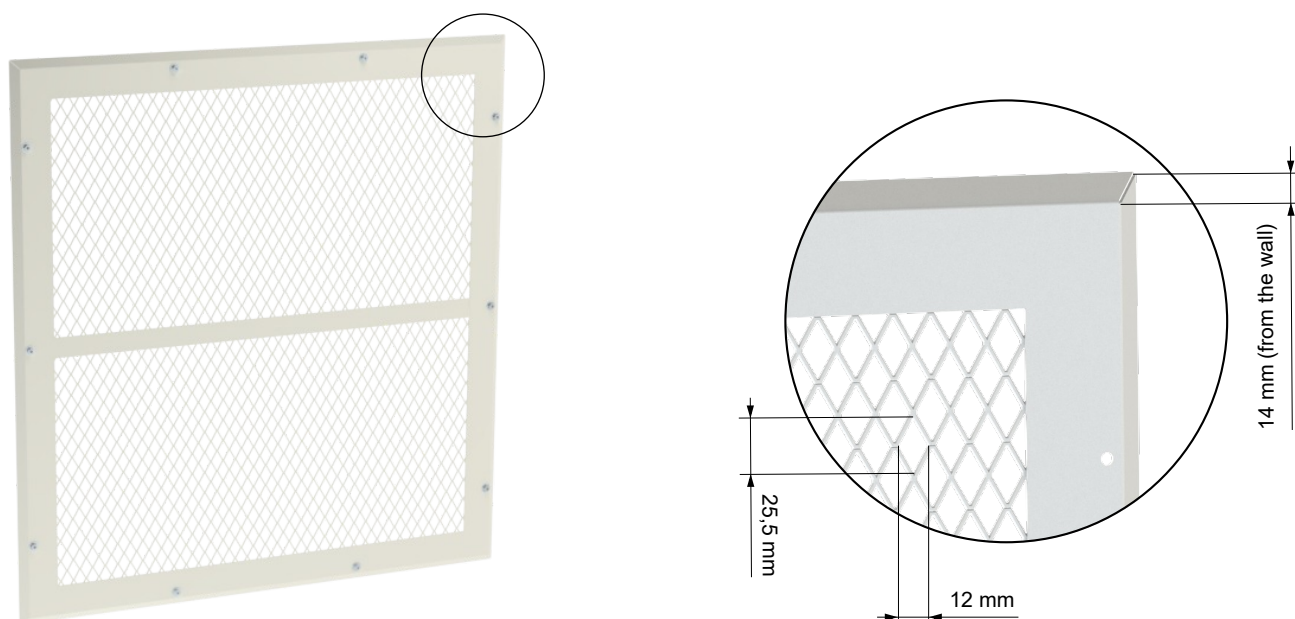

Grille G5, G6

- Design grille with aerodynamic profile and with hidden bolts louvers made of Al alloy
- These grilles are supplied on request from an external supplier. Contact the Mandík sales department.

Grille G5

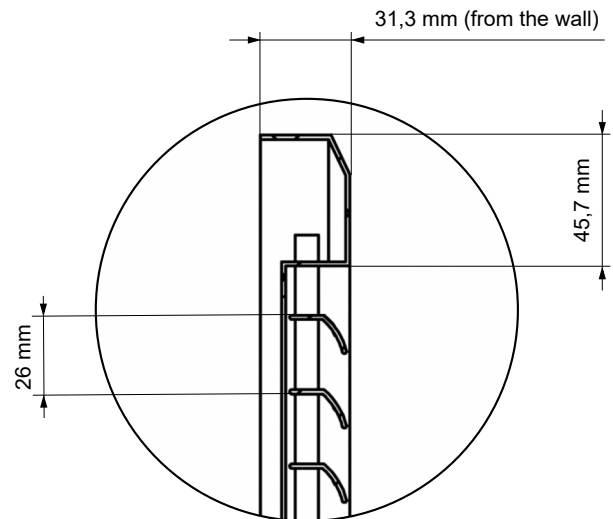

Grille G6

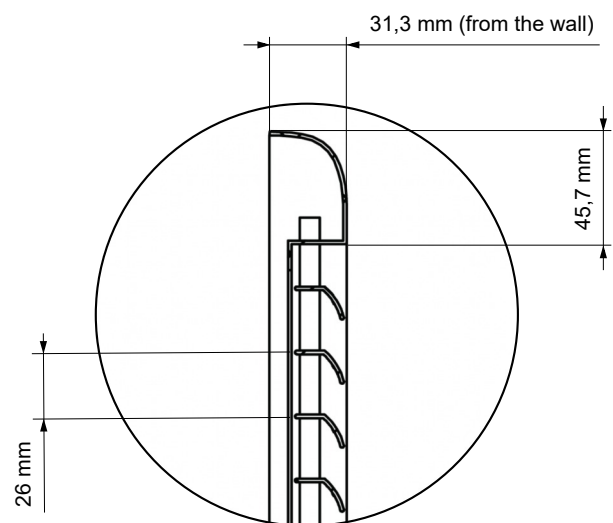
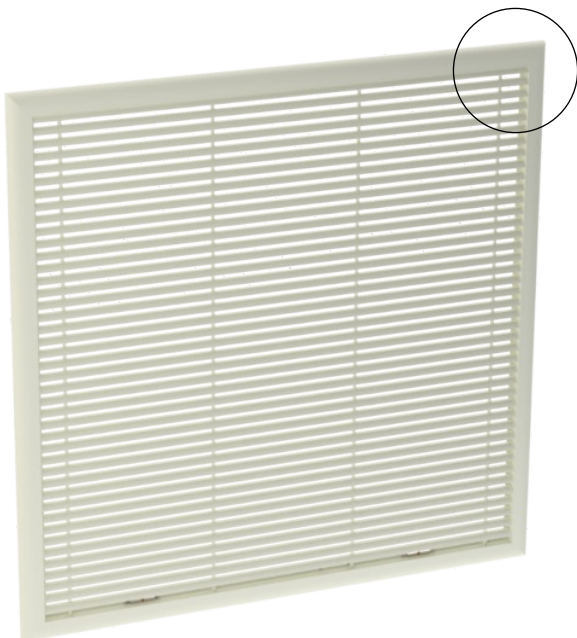

Terminal blocks and wires

1	black	MAG-	Magnet -
2	red	MAG+	Magnet +
3	-		
4	-		
5	blue	FC F1 (C)	End-switch position closed – input
6	brown	FC F2 (NO)	End-switch position closed – normally open
7	white	FC F3 (NC)	End-switch position closed – normally contact
8	violet	FC O1 (C)	End-switch position open – input
9	yellow	FC O2 (NO)	End-switch position open – normally open
10	green	FC O3 (NC)	End-switch position open – normally contact
-	-		
11	blue	FCB F1 (C)	End-switch position closed – input
12	brown	FCB F2 (NO)	End-switch position closed – normally open
13	white	FCB F3 (NC)	End-switch position closed – normally contact
14	violet	FCB O1 (C)	End-switch position open – input
15	yellow	FCB O2 (NO)	End-switch position open – normally open
16	green	FCB O3 (NC)	End-switch position open – normally contact

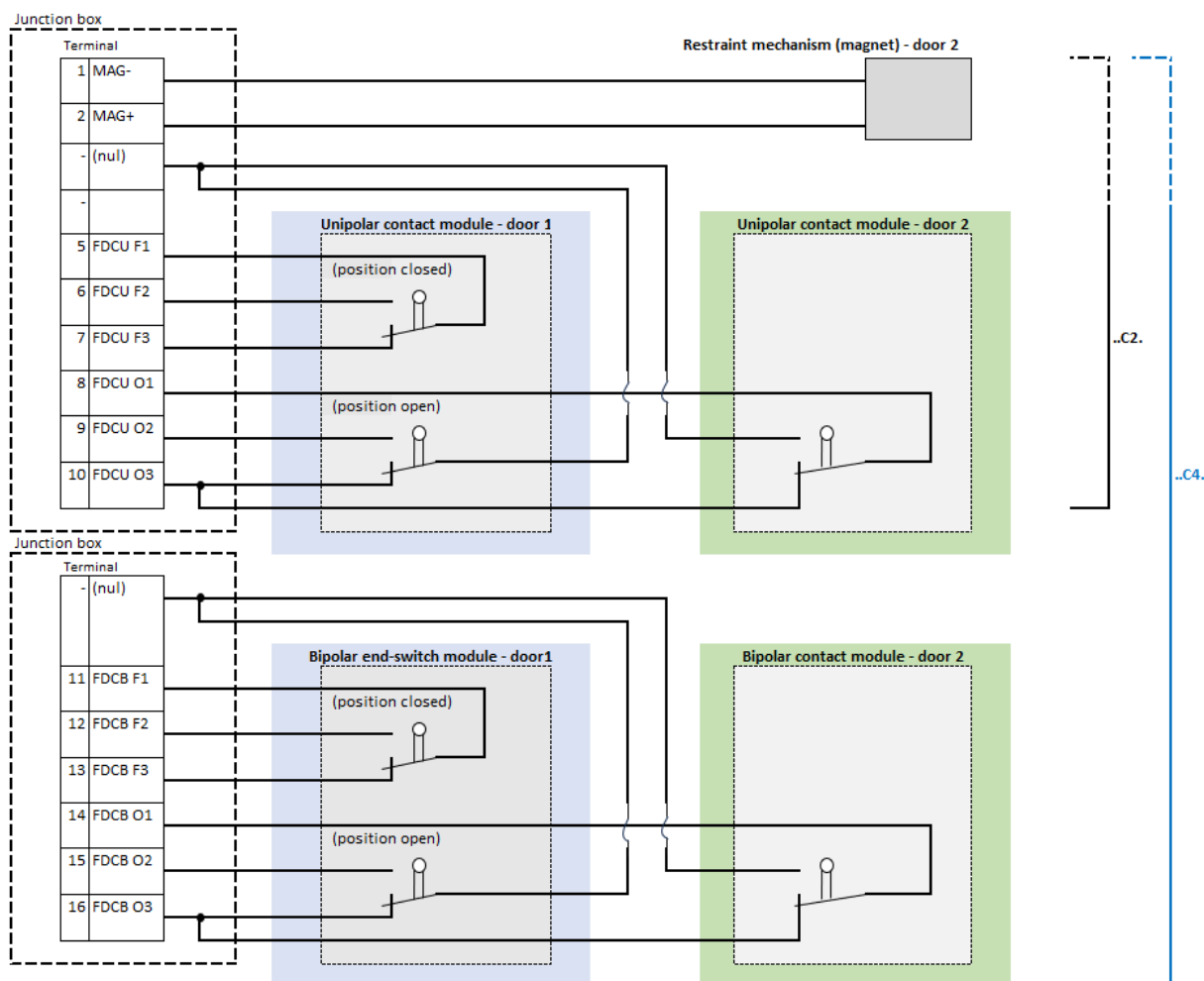

III. DAMPER CONTROL

Stand-by mode

- In the stand-by mode (the damper is closed and waiting for the activation signal) the damper does not need any supply voltage and has zero energy consumption.

Activation

- In accordance with the harmonized Standard, the damper has no self-activation function [non-autocomandé]. The damper is remotely activated [télécommande] by voltage pulse [émission du courant].
- Switch ON the voltage of 24 V DC or 48 V DC, respectively, on MAG- and MAG+ for at least 1 second to activate the damper.

Rearming

- Rearming means getting the damper back to the stand-by mode. The activation (magnet) voltage shall be safely switched off before starting the rearming process. Rearming should be carried out with the smoke extraction fan off for safety of persons and equipment.

Security position

- In the security position (position open), the damper is ready to extract smoke and heat from the fire, even if all electric connections to the damper would be disconnected. The damper has zero energy consumption if the activation voltage (magnet) is switch off (recommendation).

- To test the damper during the commissioning (with the protection grille removed or open), the damper may be activated also by-hand, by pushing the handle of the restraint mechanism in the direction to the center of the damper, as indicated on the damper by an arrow.
- After the activation, the damper opens within 5 seconds (using energy stored in springs integrated into hinges) and secures automatically in the open (security) position.

Stand-by mode (damper is closed)

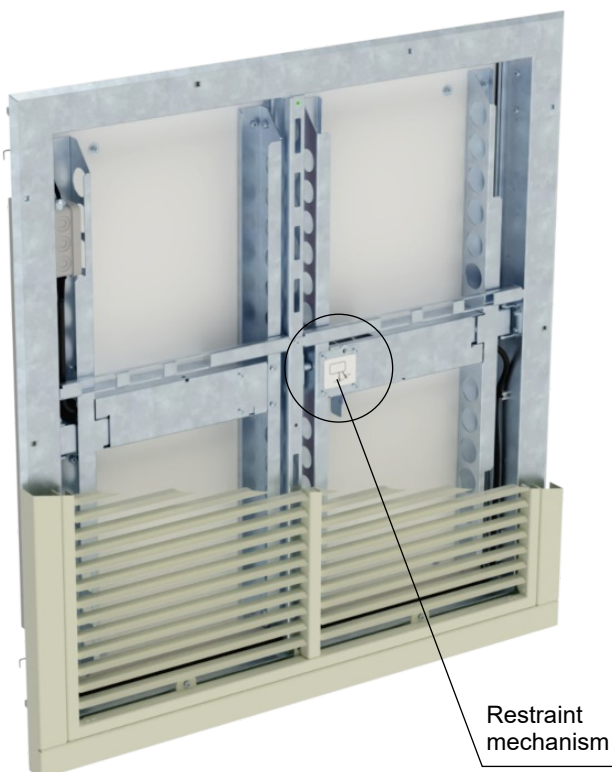

Security position (damper is open)

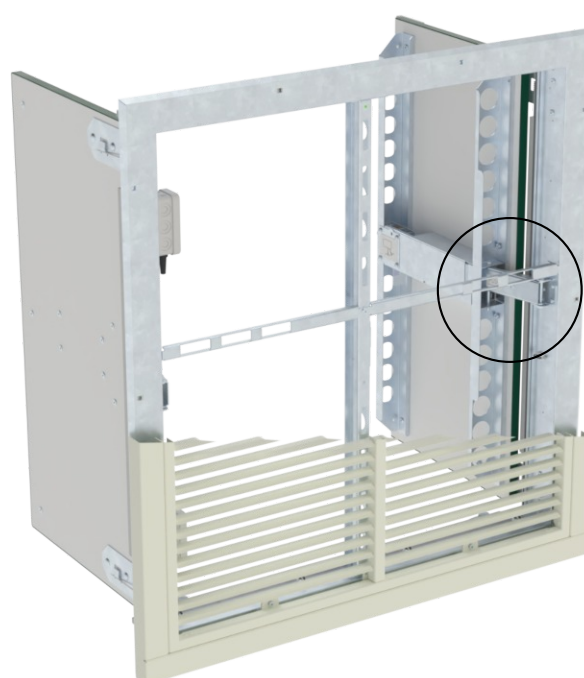

Restraint mechanism

Rearming - hand-operated design■ **The process consists of 6 steps:**

- 1) Removing or opening a protection grille
- 2) Release the damper from the open position by pushing a lever (1) marked with label PUSH
- 3) Getting the restraint mechanism (2) back to the stand-by mode by pushing its handle (3) as indicated by the arrow
- 4) Closing the damper completely
- 5) Making sure that the damper is well secured by an attempt to open the damper by pushing a blade
- 6) Installing or closing and securing the protection grille

■ **For larger dampers, it may be necessary to use both hands to rearm the damper and proceed in 7 steps:**

- 1) Removing or opening a protection grille
- 2) Release the damper from the open position by pushing a lever (1) marked with label PUSH
- 3) Closing the damper half-way
- 4) Getting the restraint mechanism (2) back to the stand-by mode by pushing its handle (3) as indicated by the arrow
- 5) Closing the damper completely
- 6) Making sure that the damper is well secured by an attempt to open the damper by pushing the blade
- 7) Installing or closing and securing the protection grille

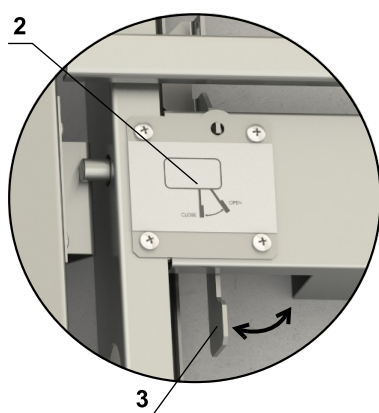
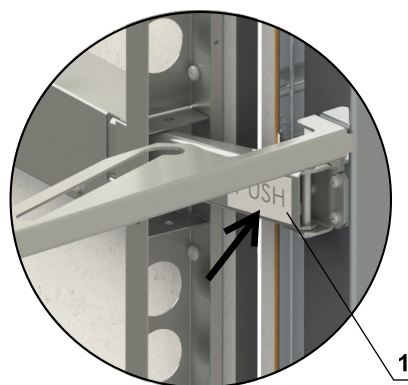
Stand-by mode (damper is closed)**Security position (damper is open)**

IV. DIMENSIONS

(Dimensions without grille)

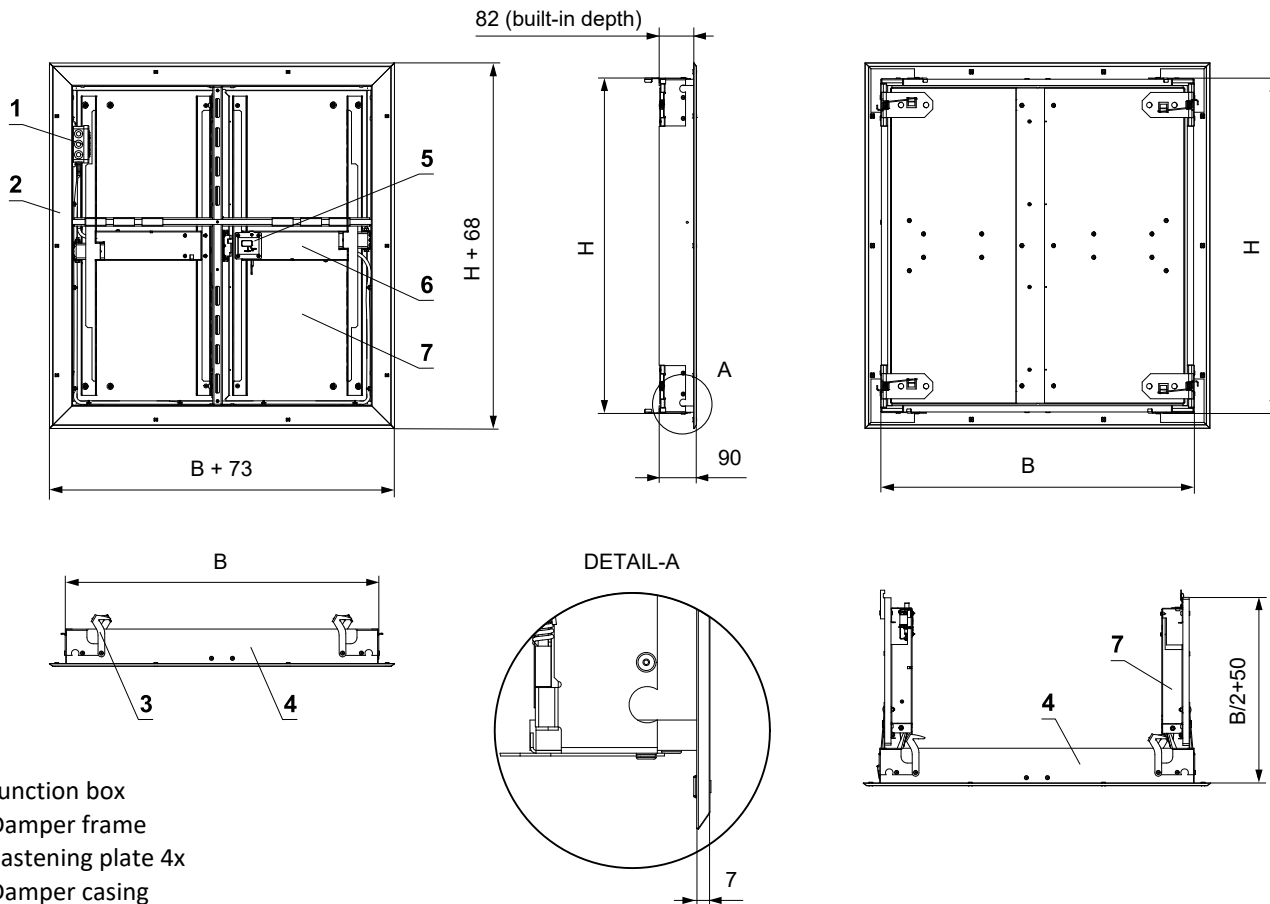

- 1 Junction box
- 2 Damper frame
- 3 Fastening plate 4x
- 4 Damper casing
- 5 Restraint mechanism
- 6 End switch module (optional)
- 7 Damper blade

(Dimensions for mounting of grilles)

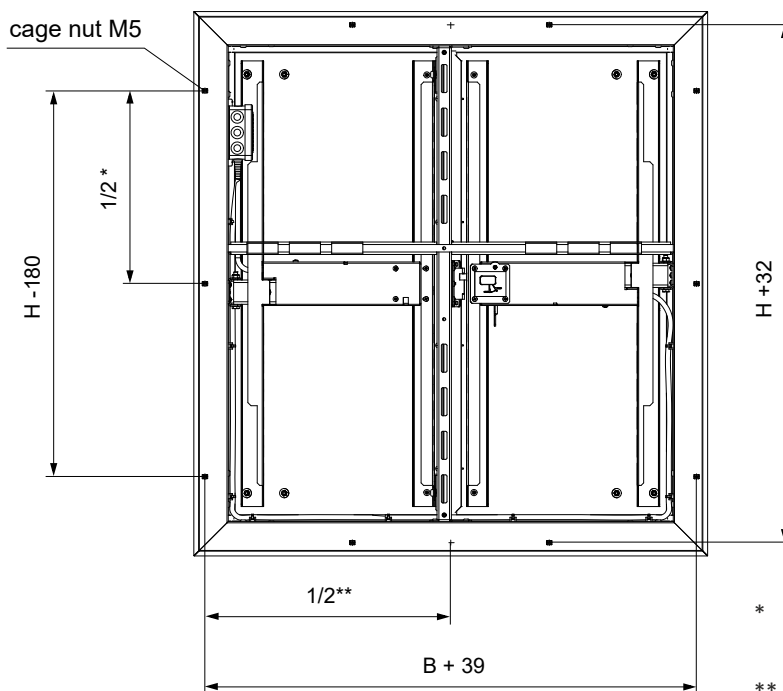

* For the side $H \leq 600$ mm, there are only two cage nuts on this side.

** For the side $B < 700$ mm, there are only one cage nut on the side.

Technical parameters

B x H [mm]	Free area S _f [m ²]	Weight [kg]						Install. frame	B x H [mm]	Free area S _f [m ²]	Weight [kg]						Install. frame	
		Damper *	G1 grille	G2 grille	G3 grille	G4 grille	Damper *				G1 grille	G2 grille	G3 grille	G4 grille				
350 x	300	0,0664	9,2	0,6	0,9	1,7	1,3	1,3	500 x	300	0,1030	11	0,8	1,2	1,9	1,6	1,5	
	350	0,0800	10,1	0,7	1	1,8	1,4	1,4		350	0,1241	12,1	0,8	1,3	2	1,7	1,6	1,6
	400	0,0936	10,9	0,7	1,2	1,9	1,5	1,4		400	0,1452	13,2	0,9	1,5	2,2	1,9	1,6	1,6
	450	0,1072	11,8	0,8	1,3	2	1,6	1,5		450	0,1663	14,2	0,9	1,6	2,3	2	1,7	1,7
	500	0,1208	12,6	0,8	1,4	2,2	1,7	1,6		500	0,1874	15,3	1	1,8	2,5	2,1	1,8	1,8
	550	0,1344	13,5	0,9	1,6	2,3	1,9	1,6		550	0,2085	16,4	1,1	2	2,6	2,3	1,8	1,8
	600	0,1425	14,7	0,9	1,7	2,5	2	1,7		600	0,2211	17,9	1,1	2,2	2,9	2,4	1,9	1,9
	650	0,1561	15,5	1	1,8	2,6	2,1	1,8		650	0,2422	18,9	1,2	2,3	3	2,5	2	2
	700	0,1697	16,4	1	1,9	2,8	2,2	1,8		700	0,2633	20	1,3	2,5	3,1	2,7	2,1	2,1
	750	0,1833	17,3	1,1	2	2,9	2,3	1,9		750	0,2844	21,2	1,3	2,6	3,3	2,8	2,1	2,1
	800	0,1969	18,2	1,2	2,2	3	2,4	2		800	0,3055	22,3	1,4	2,8	3,4	3	2,3	2,3
400 x	850	0,2105	19,1	1,2	2,3	3,1	2,6	2,1	850	0,3266	23,4	1,5	2,9	3,5	3,1	2,4	2,4	
	900	0,2241	20	1,3	2,4	3,2	2,7	2,2	900	0,3477	24,5	1,5	3,1	3,6	3,2	2,4	2,4	
	950	0,2377	20,9	1,3	2,5	3,3	2,8	2,3	950	0,3688	25,6	1,6	3,2	3,8	3,4	2,5	2,5	
	1000	0,2513	21,7	1,4	2,6	3,4	2,9	2,3	1000	0,3899	26,7	1,7	3,4	3,9	3,7	2,6	2,6	
	1050	0,2649	22,6	1,4	2,8	3,5	3	2,4	1050	0,4110	27,8	1,7	3,5	4	3,8	2,7	2,7	
	1105	0,2799	23,6	1,5	2,9	3,6	3,2	2,5	1105	0,4342	29	1,8	3,7	4,1	3,9	2,8	2,8	
	300	0,0786	9,8	0,6	1	1,8	1,4	1,4	300	0,1152	11,6	0,8	1,5	2	1,7	1,6	1,6	
	350	0,0947	10,8	0,7	1,1	1,9	1,5	1,4	350	0,1388	12,8	0,9	1,6	2,1	1,9	1,6	1,6	
	400	0,1108	11,7	0,8	1,3	2	1,6	1,5	400	0,1624	13,9	0,9	1,8	2,3	2	1,7	1,7	
	450	0,1269	12,6	0,8	1,4	2,1	1,8	1,6	450	0,1860	15,1	1	2	2,4	2,1	1,8	1,8	
	500	0,1430	13,5	0,9	1,5	2,3	1,9	1,6	500	0,2096	16,2	1,1	2,2	2,6	2,3	1,8	1,8	
550	0,1591	14,5	0,9	1,7	2,4	2	1,7	550	0,2332	17,4	1,1	2,4	2,7	2,4	1,9	1,9		
600	0,1687	15,7	1	1,9	2,6	2,1	1,8	600	0,2473	18,9	1,2	2,5	3	2,6	2	2		
650	0,1848	16,7	1,1	2	2,8	2,2	1,8	650	0,2709	20,1	1,3	2,7	3,1	2,7	2,1	2,1		
700	0,2009	17,6	1,1	2,1	2,9	2,4	1,9	700	0,2945	21,3	1,4	2,9	3,3	2,9	2,1	2,1		
750	0,2170	18,6	1,2	2,2	3	2,5	2	750	0,3181	22,5	1,4	3	3,4	3	2,2	2,2		
800	0,2331	19,6	1,2	2,4	3,1	2,6	2,1	800	0,3417	23,7	1,5	3,2	3,5	3,1	2,4	2,4		
850	0,2492	20,5	1,3	2,5	3,2	2,7	2,2	850	0,3653	24,8	1,6	3,3	3,7	3,3	2,5	2,5		
900	0,2653	21,5	1,4	2,6	3,3	2,8	2,3	900	0,3889	26	1,6	3,5	3,8	3,6	2,5	2,5		
950	0,2814	22,5	1,4	2,8	3,5	3	2,4	950	0,4125	27,2	1,7	3,7	3,9	3,7	2,6	2,6		
1000	0,2975	23,4	1,5	2,9	3,6	3,1	2,4	1000	0,4361	28,4	1,8	3,9	4	3,9	2,7	2,7		
1050	0,3136	24,4	1,5	3	3,7	3,2	2,5	1050	0,4597	29,6	1,8	4	4,2	4	2,7	2,7		
1105	0,3313	25,4	1,6	3,2	3,8	3,4	2,6	1105	0,4857	30,8	1,9	4,2	4,3	4,2	2,8	2,8		
450 x	300	0,0908	8,5	0,7	1,1	1,8	1,5	1,4	300	0,1274	12,2	0,9	1,6	2,1	1,8	1,6	1,6	
	350	0,1094	11,4	0,8	1,2	1,9	1,6	1,5	350	0,1535	13,2	0,9	1,7	2,2	2	1,7	1,7	
	400	0,1280	12,4	0,8	1,4	2,1	1,8	1,6	400	0,1796	14,2	1	1,9	2,3	2,1	1,8	1,8	
	450	0,1466	13,4	0,9	1,5	2,2	1,9	1,6	450	0,2057	15,2	1,1	2,1	2,5	2,3	1,8	1,8	
	500	0,1652	14,4	0,9	1,7	2,4	2	1,7	500	0,2318	16,2	1,1	2,3	2,7	2,4	1,9	1,9	
	550	0,1838	15,4	1	1,9	2,5	2,1	1,8	550	0,2579	17,2	1,2	2,5	2,8	2,6	2	2	
	600	0,1949	16,8	1,1	2	2,8	2,3	1,8	600	0,2735	18,7	1,3	2,7	3,1	2,7	2,2	2,2	
	650	0,2135	17,8	1,1	2,1	2,9	2,4	1,9	650	0,2996	19,7	1,4	2,9	3,3	2,9	2,3	2,3	
	700	0,2321	18,8	1,2	2,3	3	2,5	2	700	0,3257	20,7	1,4	3,1	3,4	3	2,3	2,3	
	750	0,2507	19,9	1,3	2,4	3,1	2,6	2,1	750	0,3518	21,8	1,5	3,2	3,5	3,2	2,4	2,4	
	800	0,2693	20,9	1,3	2,6	3,2	2,8	2,2	800	0,3779	22,8	1,6	3,4	3,7	3,3	2,6	2,6	
850	0,2879	22	1,4	2,7	3,4	2,9	2,3	850	0,4040	23,8	1,7	3,6	3,8	3,7	2,7	2,7		
900	0,3065	23	1,4	2,9	3,5	3,1	2,4	900	0,4301	24,9	1,7	3,8	4	3,8	2,7	2,7		
950	0,3251	24	1,5	3,0	3,6	3,2	2,4	950	0,4562	26	1,8	3,9	4,1	4	2,8	2,8		
1000	0,3437	25,1	1,6	3,2	3,7	3,3	2,5	1000	0,4823	27	1,9	4,1	4,2	4,1	2,9	2,9		
1050	0,3623	26,1	1,6	3,3	3,9	3,4	2,6	1050	0,5084	28	1,9	4,3	4,4	4,2	2,9	2,9		
1105	0,3828	27,2	1,7	3,4	4	3,7	2,7	1105	0,5371	29,1	2	4,5	4,5	4,4	3	3		

Sizes in increments of 5 mm can be manufactured on request.

* For designs with end switch module a weight of 0,17 kg must be added.

B x H [mm]	Free area S _f [m ²]	Weight [kg]						Install. frame	B x H [mm]	Free area S _f [m ²]	Weight [kg]						Install. frame
		Damper *	G1 grille	G2 grille	G3 grille	G4 grille					Damper *	G1 grille	G2 grille	G3 grille	G4 grille		
650 x	300	0,1396	12,8	0,9	1,7	2,1	1,9	1,7	800 x	300	0,1762	14,4	1,1	2,1	2,9	2,2	2
	350	0,1682	13,8	1	1,8	2,3	2,1	1,8		350	0,2123	15,6	1,2	2,2	3	2,4	2
	400	0,1968	14,9	1,1	2	2,4	2,2	1,8		400	0,2484	16,8	1,2	2,4	3,1	2,6	2,1
	450	0,2254	15,9	1,1	2,2	2,6	2,4	1,9		450	0,2845	18	1,3	2,6	3,2	2,8	2,2
	500	0,2540	17,0	1,2	2,4	2,8	2,5	2		500	0,3206	19,2	1,4	2,8	3,4	3	2,3
	550	0,2826	18,0	1,3	2,6	2,9	2,7	2,1		550	0,3567	20,4	1,5	3,2	3,5	3,1	2,4
	600	0,2997	19,5	1,4	2,9	3,2	2,9	2,3		600	0,3783	22,1	1,6	3,4	3,7	3,3	2,6
	650	0,3283	20,6	1,4	3	3,4	3	2,3		650	0,4144	23,3	1,7	3,6	3,8	3,7	2,7
	700	0,3569	21,6	1,5	3,2	3,5	3,2	2,4		700	0,4505	24,5	1,7	3,8	3,9	3,9	2,8
	750	0,3855	22,8	1,6	3,4	3,7	3,3	2,5		750	0,4866	25,8	1,8	4	4,1	4,1	2,9
	800	0,4141	23,9	1,7	3,6	3,8	3,7	2,7		800	0,5227	27	1,9	4,3	4,2	4,3	3
850	0,4427	24,9	1,7	3,8	4	3,9	2,7	850	0,5588	28,2	2	4,4	4,4	4,4	3,1		
900	0,4713	26,0	1,8	4	4,1	4	2,8	900	0,5949	29,4	2,1	4,7	4,6	4,6	3,2		
950	0,4999	27,1	1,9	4,1	4,2	4,2	2,9	950	0,6310	30,7	2,2	4,9	4,7	4,8	3,3		
1000	0,5285	28,2	2	4,4	4,4	4,3	3	1000	0,6671	31,9	2,3	5,1	4,9	4,9	3,4		
1050	0,5571	29,3	2	4,5	4,6	4,5	3	1050	0,7032	33,1	2,3	5,3	5,1	5,1	3,5		
1105	0,5886	30,4	2,1	4,7	4,7	4,6	3,1	1105	0,7429	34,4	2,4	5,6	5,3	5,3	3,6		
700 x	300	0,1518	13,3	1	1,8	2,2	2,1	1,8	850 x	300	0,1884	15	1,1	2,2	3	2,4	2,1
	350	0,1829	14,4	1	1,9	2,4	2,2	1,8		350	0,2270	16,2	1,2	2,3	3,1	2,6	2,1
	400	0,2140	15,5	1,1	2,2	2,5	2,4	1,9		400	0,2656	17,5	1,3	2,5	3,2	2,7	2,2
	450	0,2451	16,6	1,2	2,3	2,7	2,5	2		450	0,3042	18,7	1,4	2,7	3,4	2,9	2,3
	500	0,2762	17,7	1,3	2,6	2,9	2,7	2,1		500	0,3428	20	1,5	2,9	3,5	3,1	2,4
	550	0,3073	18,8	1,4	2,8	3	2,9	2,1		550	0,3814	21,2	1,6	3,3	3,7	3,3	2,5
	600	0,3259	20,4	1,4	3	3,4	3	2,3		600	0,4045	22,9	1,7	3,6	3,8	3,7	2,7
	650	0,3570	21,5	1,5	3,2	3,5	3,2	2,4		650	0,4431	24,2	1,7	3,8	4	3,9	2,7
	700	0,3881	22,6	1,6	3,4	3,7	3,6	2,5		700	0,4817	25,4	1,8	4	4,1	4	2,8
	750	0,4192	23,8	1,7	3,6	3,8	3,7	2,5		750	0,5203	26,8	1,9	4,1	4,2	4,3	2,9
	800	0,4503	24,9	1,7	3,8	3,9	3,9	2,7		800	0,5589	28	2	4,4	4,4	4,4	3
850	0,4814	26,0	1,8	4	4,1	4	2,8	850	0,5975	29,3	2,1	4,6	4,6	4,6	3,1		
900	0,5125	27,1	1,9	4,2	4,3	4,2	2,9	900	0,6361	30,5	2,2	4,9	4,7	4,8	3,2		
950	0,5436	28,3	2	4,4	4,4	4,4	3	950	0,6747	31,9	2,3	5,1	4,9	5	3,3		
1000	0,5747	29,4	2,1	4,6	4,6	4,5	3	1000	0,7133	33,1	2,4	5,4	5,1	5,2	3,4		
1050	0,6058	30,5	2,1	4,8	4,7	4,7	3,1	1050	0,7519	34,4	2,5	5,6	5,3	5,3	3,5		
1105	0,6400	31,7	2,2	5	4,9	4,8	3,2	1105	0,7944	35,7	2,5	5,8	5,4	5,5	3,6		
750 x	300	0,1640	13,9	1	1,9	2,8	2,1	1,8	900 x	300	0,2006	15,3	1,2	2,3	3,1	2,5	2,1
	350	0,1976	15,0	1,1	2	2,9	2,3	1,9		350	0,2417	16,6	1,3	2,4	3,2	2,7	2,2
	400	0,2312	16,2	1,2	2,2	3	2,5	2		400	0,2828	17,9	1,4	2,6	3,3	2,8	2,3
	450	0,2648	17,3	1,2	2,4	3,1	2,6	2,1		450	0,3239	19,2	1,4	2,9	3,5	3,1	2,4
	500	0,2984	18,5	1,3	2,6	3,3	2,8	2,1		500	0,3650	20,5	1,5	3,1	3,6	3,2	2,4
	550	0,3320	19,6	1,4	3	3,4	3	2,2		550	0,4061	21,7	1,6	3,5	3,8	3,6	2,5
	600	0,3521	21,2	1,5	3,2	3,5	3,2	2,4		600	0,4307	23,5	1,7	3,8	4	3,8	2,7
	650	0,3857	22,4	1,6	3,4	3,7	3,3	2,5		650	0,4718	24,8	1,8	4	4,1	4	2,8
	700	0,4193	23,6	1,7	3,6	3,8	3,7	2,5		700	0,5129	26,1	1,9	4,2	4,3	4,2	2,9
	750	0,4529	24,8	1,8	3,8	3,9	3,9	2,6		750	0,5540	27,5	2	4,6	4,4	4,5	3
	800	0,4865	26,0	1,8	4	4,1	4,1	2,8		800	0,5951	28,8	2,1	4,9	4,5	4,6	3,1
850	0,5201	27,1	1,9	4,2	4,3	4,2	2,9	850	0,6362	30,1	2,2	5,1	4,7	4,8	3,2		
900	0,5537	28,3	2	4,4	4,4	4,4	3	900	0,6773	31,4	2,3	5,4	4,9	5	3,3		
950	0,5873	29,5	2,1	4,6	4,6	4,6	3,1	950	0,7184	32,8	2,4	5,6	5,1	5,2	3,4		
1000	0,6209	30,7	2,2	4,9	4,7	4,7	3,2	1000	0,7595	34,1	2,5	5,9	5,2	5,4	3,5		
1050	0,6545	31,8	2,2	5	4,9	4,9	3,3	1050	0,8006	35,4	2,6	6,1	5,5	5,5	3,6		
1105	0,6915	33,1	2,3	5,3	5,1	5,1	3,4	1105	0,8458	36,8	2,6	6,4	5,6	5,7	3,7		

Sizes in increments of 5 mm can be manufactured on request.

* For designs with end switch module a weight of 0,17 kg must be added.

B x H [mm]	Free area S _f [m ²]	Weight [kg]						Install. frame	B x H [mm]	Free area S _f [m ²]	Weight [kg]						Install. frame
		Damper *	G1 grille	G2 grille	G3 grille	G4 grille					Damper *	G1 grille	G2 grille	G3 grille	G4 grille		
950 x	300	0,2128	15,9	1,2	2,3	3,2	2,7	2,2	1050 x	300	0,2372	16,9	1,3	2,6	3,4	2,8	2,3
	350	0,2564	17,2	1,3	2,5	3,3	2,8	2,3		350	0,2858	18,4	1,4	2,8	3,5	3	2,4
	400	0,3000	18,5	1,4	2,8	3,5	3	2,4		400	0,3344	19,8	1,5	3	3,7	3,2	2,5
	450	0,3436	19,9	1,5	3	3,6	3,2	2,4		450	0,3830	21,2	1,6	3,3	3,9	3,4	2,6
	500	0,3872	21,2	1,6	3,2	3,8	3,4	2,5		500	0,4316	22,6	1,7	3,5	4	3,8	2,7
	550	0,4308	22,5	1,7	3,7	3,9	3,7	2,6		550	0,4802	24	1,8	4	4,2	4	2,7
	600	0,4569	24,4	1,8	3,9	4,1	4	2,8		600	0,5093	26,1	1,9	4,3	4,4	4,2	2,9
	650	0,5005	25,7	1,9	4,1	4,2	4,2	2,9		650	0,5579	27,5	2	4,5	4,6	4,5	3
	700	0,5441	27,1	2	4,4	4,4	4,4	3		700	0,6065	28,9	2,1	4,8	4,7	4,7	3,1
	750	0,5877	28,5	2,1	4,8	4,6	4,6	3,1		750	0,6551	30,5	2,2	5,2	4,9	5	3,2
	800	0,6313	29,9	2,2	5,1	4,8	4,8	3,2		800	0,7037	31,9	2,3	5,6	5,1	5,2	3,3
850	0,6749	31,2	2,3	5,3	5	5	3,3	850	0,7523	33,3	2,5	5,8	5,4	5,4	3,4		
900	0,7185	32,5	2,4	5,6	5,2	5,2	3,4	900	0,8009	34,8	2,6	6,1	5,5	5,6	3,5		
950	0,7621	34	2,5	5,8	5,4	5,4	3,5	950	0,8495	36,3	2,7	6,4	5,7	5,8	3,6		
1000	0,8057	35,3	2,6	6,1	5,6	5,6	3,6	1000	0,8981	37,7	2,8	6,7	5,9	6	3,7		
1050	0,8493	36,7	2,7	6,3	5,8	5,8	3,7	1050	0,9467	39,2	2,9	6,9	6,2	6,2	3,8		
1105	0,8973	38,1	2,8	6,6	6	5,9	3,8	1105	0,9953	40,7	3	7,2	6,4	6,4	3,9		
1000 x	300	0,2250	16,4	1,3	2,5	3,3	2,7	2,3	1105 x	300	0,2506	17,5	1,4	2,7	3,4	3	2,4
	350	0,2711	17,8	1,4	2,6	3,4	2,9	2,3		350	0,3019	19	1,5	2,9	3,6	3,2	2,5
	400	0,3172	19,1	1,5	2,9	3,6	3,1	2,4		400	0,3533	20,4	1,6	3,2	3,8	3,4	2,6
	450	0,3633	20,5	1,6	3,2	3,7	3,3	2,5		450	0,4046	21,9	1,7	3,4	4	3,7	2,7
	500	0,4094	21,9	1,7	3,4	3,9	3,7	2,6		500	0,4560	23,4	1,8	3,7	4,1	3,9	2,8
	550	0,4555	23,3	1,8	3,9	4	3,9	2,7		550	0,5073	24,8	1,9	4,2	4,3	4,2	2,8
	600	0,4831	25,2	1,9	4,1	4,2	4,1	2,9		600	0,5381	26,9	2	4,5	4,5	4,4	3
	650	0,5292	26,6	2	4,4	4,4	4,3	3		650	0,5895	28,4	2,1	4,7	4,7	4,6	3,1
	700	0,5753	28	2,1	4,6	4,6	4,5	3		700	0,6408	29,9	2,2	5	4,9	4,8	3,2
	750	0,6214	29,5	2,2	5	4,8	4,8	3,1		750	0,6922	31,4	2,3	5,4	5	5,2	3,3
	800	0,6675	30,8	2,3	5,3	5	5	3,2		800	0,7435	32,9	2,4	5,7	5,2	5,4	3,4
850	0,7136	32,2	2,4	5,5	5,2	5,2	3,3	850	0,7949	34,4	2,5	6	5,5	5,6	3,5		
900	0,7597	33,6	2,5	5,8	5,4	5,4	3,4	900	0,8462	35,9	2,6	6,3	5,7	5,8	3,6		
950	0,8058	35,1	2,6	6	5,6	5,6	3,5	950	0,8976	37,4	2,8	6,6	5,9	6	3,7		
1000	0,8519	36,5	2,7	6,3	5,8	5,8	3,6	1000	0,9489	38,9	2,9	6,9	6,1	6,2	3,8		
1050	0,8980	37,9	2,8	6,6	6	6	3,7	1050	1,0003	40,4	3	7,2	6,4	6,4	3,9		
1105	0,9487	39,4	2,9	6,9	6,2	6,2	3,8	1105	1,0568	42	3,1	7,5	6,6	6,6	4		

Sizes in increments of 5 mm can be manufactured on request.

* For designs with end switch module a weight of 0,17 kg must be added.

V. INSTALLATION

Placement and Installation

- The dampers are suitable for vertical installation only. Damper installation procedures must be done so that all load transfer from the construction to the damper is absolutely excluded. The gap between the installed damper and the construction, or between the installation frame and the construction must be perfectly filled with approved material.
- Once the damper is built in, the damper blade should not grind against the damper casing during opening or closing.
- The distance between the damper and the construction must be 75 mm at the minimum, according to EN 1366-10. If two or more dampers are to be installed in one construction, the distance between adjacent dampers must be 200 mm at the minimum, according to EN 1366-10.

Minimum distance between dampers and the construction

- minimum distance 200 mm between dampers, according to EN 1366-10
- minimum distance 75 mm between the damper and the construction, according to EN 1366-10

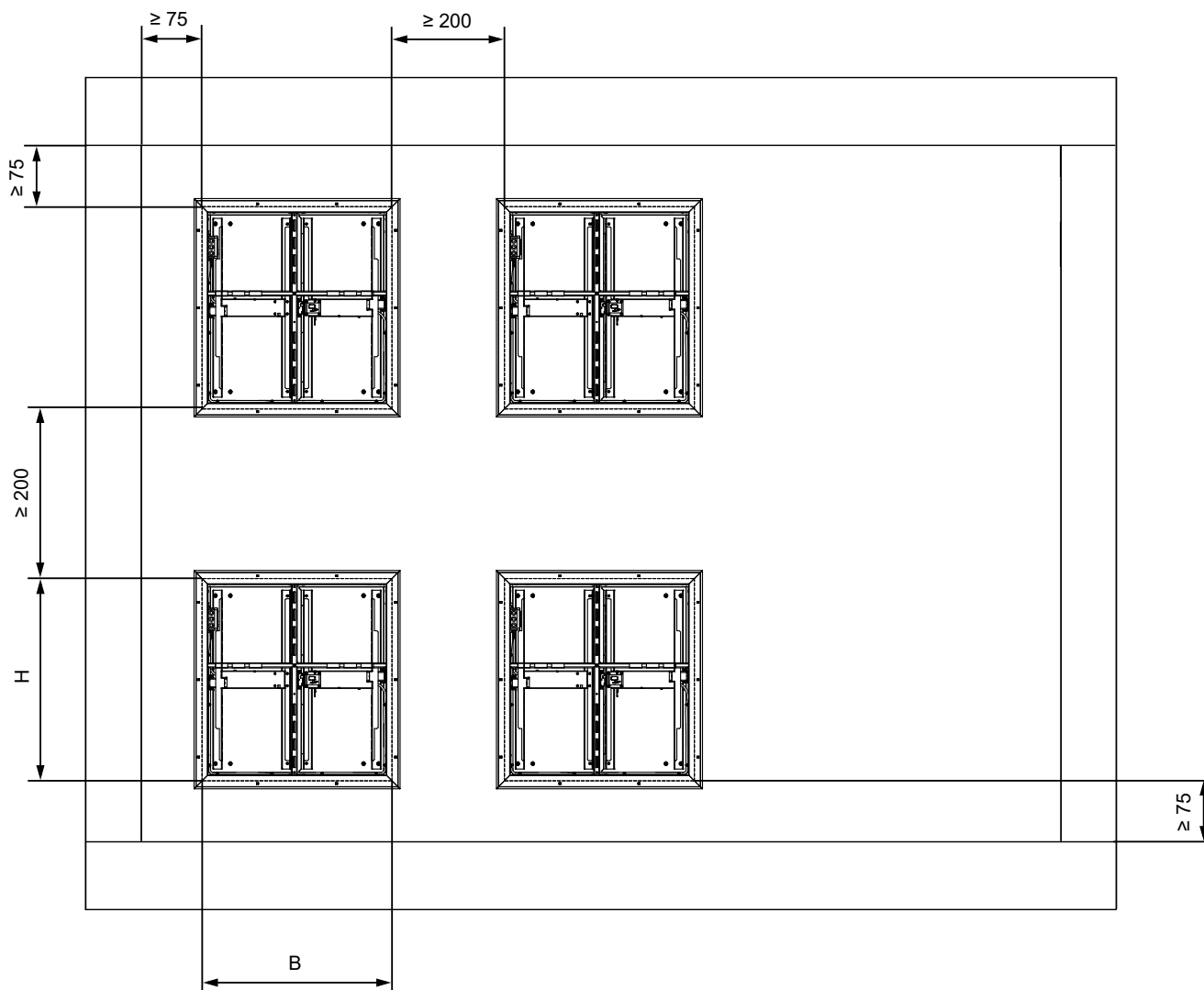

Statement of installations

Installation	shaft wall min. thickness [mm]	Filling the gap between the damper and a shaft wall	Fire resistance	Page
Shaft from concrete or aerated concrete	70	Mastic	EI 120 (v _{ed}) S1500[V]C ₃₀₀ (N)AAmulti	25
		Installation frame - mastic		26
Shaft from fire-resistant panels				
<ul style="list-style-type: none"> – specific weight min 500 kg/m – shaft wall thickness min. 30 mm while respecting shaft wall thickness in accordance with the given duct fire resistance class* for the given pressure; e.g.: <ul style="list-style-type: none"> • 50 mm PROMATECT L 500 • 45 mm THERMAX SL (Tecniver) • 45 mm GEOTEC S • 45 mm GEOFLAM F • 35 mm GEOFLAM F Light 		Mastic	EI 120 (v _{ed}) S1500[V]C ₃₀₀ (N)AAmulti	27
		Installation frame - mastic		28
Shaft from fire-resistant panels				
<ul style="list-style-type: none"> – specific weight min 500 kg/m – shaft wall thickness min. 30 mm while respecting shaft wall thickness in accordance with the given duct fire resistance class* for the given pressure; e.g.: <ul style="list-style-type: none"> • 40 mm PROMATECT L 500 • 45 mm THERMAX SL (Tecniver) • 45 mm GEOTEC S • 35 mm GEOFLAM F • 35 mm GEOFLAM F Light 		Mastic	EI 90 (v _{ed}) S1500[V]C ₃₀₀ (N)AAmulti	27
		Installation frame - mastic		28
Shaft from fire-resistant panels				
<ul style="list-style-type: none"> – specific weight min 500 kg/m – shaft wall thickness min. 30 mm while respecting shaft wall thickness in accordance with the given duct fire resistance class* for the given pressure; e.g.: <ul style="list-style-type: none"> • 30 mm PROMATECT L 500 • 45 mm THERMAX SL (Tecniver) • 30 mm GEOTEC S • 30 mm GEOFLAM F • 35 mm GEOFLAM F Light 		Mastic	EI 60 (v _{ed}) S1500[V]C ₃₀₀ (N)AAmulti	27
		Installation frame - mastic		28
Shaft from fire-resistant panels				
<ul style="list-style-type: none"> – specific weight min 500 kg/m – shaft wall thickness min. 30 mm while respecting shaft wall thickness in accordance with the given duct fire resistance class* for the given pressure; e.g.: <ul style="list-style-type: none"> • 35 mm THERMAX SL (Tecniver) 		Mastic	EI 60 (v _{ed}) S500[V]C ₃₀₀ (N)AAmulti	27
		Installation frame - mastic		28

* Duct system must be tested and classified in accordance with EN 13501-4

Installation procedure

Approved damper installation positions

- The damper must be installed only in the approved positions shown in the pictures below.

Correct installation position $H < 570$

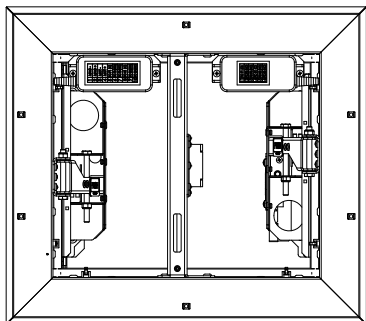

Correct installation position $H \geq 570$

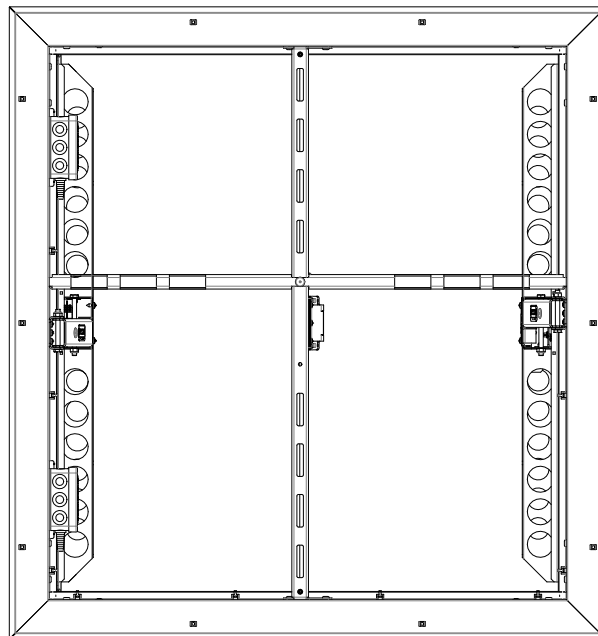

Installation without installation frame

- 1) Drill a hole in the corner of the damper for a connecting cable, prepare a cable passage in the shaft wall.
- 2) Check that all cage nuts or other elements necessary for the connection of the grille are on the damper.
- 3) Fill the inside of the damper frame with mastic.
- 4) Install SEDM-2D into the center of installation opening using wedges or spacers.
- 5) Pull the connecting cable including a special grommet through the wall.
- 6) Fill the gap between the damper and a shaft with mastic. Make sure that the gap is perfectly filled. Let the mastic harden.
- 7) Drill four holes to the damper casing in the place of corners (4 x horizontal) up to the shaft wall, screw the damper into the shaft wall.
- 8) Connect the cable to the junction box, secure the cable on the inside of the damper casing against pulling the end out of the junction box using cable clips.
- 9) Seal the cable passage through the shaft wall and through the damper casing.
- 10) Attach a shock absorber to the shaft wall or damper blade.
- 11) Test opening and closing of the damper blade.
- 12) Install a grille.

Installation with installation frame

- 1) Install frame into the opening. For frame installation procedure → see page 23
- 2) Drill a hole in the corner of the damper for a connecting cable, prepare a cable passage in the shaft wall.
- 3) Check that all cage nuts or other elements necessary for the connection of the grille are on the damper.
- 4) Install SEDM-2D on the frame and mount it on four fastening plates.
- 5) Pull the connecting cable including the special grommet through the shaft wall.
- 6) Connect the cable to the junction box, secure the cable on the inside of the damper casing against pulling the end out of the junction box using cable clips.
- 7) Seal the cable passage through the shaft wall and through the damper casing.
- 8) Attach a shock absorber to the shaft wall or damper blade.
- 9) Test opening and closing of the damper blade.
- 10) Install a grille.

Cable connection

1) Choose one of the 8 pre-punched holes in the corners for the easiest way of cable connection. Drill a hole through the damper. Prepare a cable passage in the shaft wall.

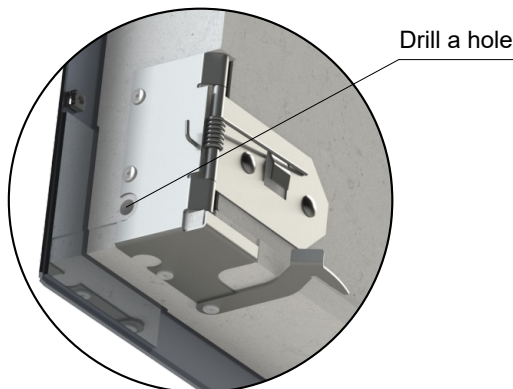

2) Install cable clips on the damper frame. There are pre-drilled holes in the frame for cable clips. The cable clips are delivered with the damper.

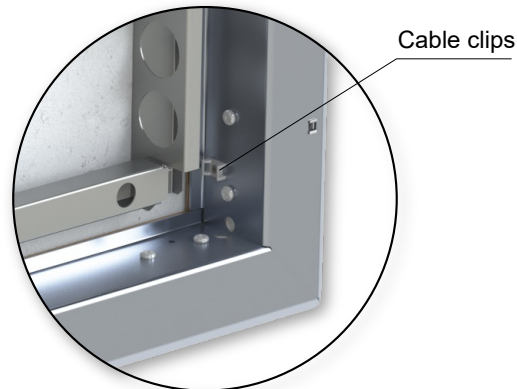

3) Electric connection to the junction box should be made **preferably with a cable coming from the bottom**. For bottom connection, those combinations of the elements are allowed:

- Soft cable gland of IP 42 min (grommet 1251347 – Essentra), fixing the user cable by anti-traction on the junction box + additional anti-traction clip on the damper frame.
- Bolt-type cable gland of size PG 7 max with hexagon 15 max key size (SKINTOP STR PG 7 LAPP Group) as reference combined with a round user cable.

Should the connection to the junction to be made with a cable coming from the top, only this combination of the elements is allowed:

- Bolt-type cable gland(s) of size PG 7 max with hexagon 15 max key size (SKINTOP STR PG 7 LAPP Group) combined with a round user cable(s).

For the connection from the top, it is forbidden to use any other type of passage through the wall of the junction box (as soft cable glands, bundle of individual wires, double line cable, passage of a round cable through the wall, etc.).

In all cases, cable(s) should be secured against being pulled out of the junction box. Always test the effectiveness of the anti-traction measures after the installation.

4) **Make sure that the cable does not obstruct opening and closing of the damper blade. Check that the cable is not pinched when opening or closing the damper blade!** The cable can be pulled behind the lever or through the hole in the centre reinforcement. Seal the cable passage through the shaft wall and through the damper casing.

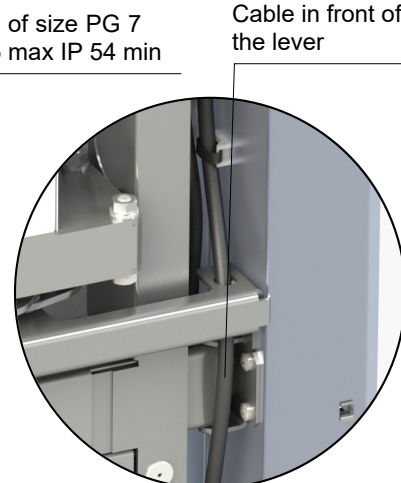
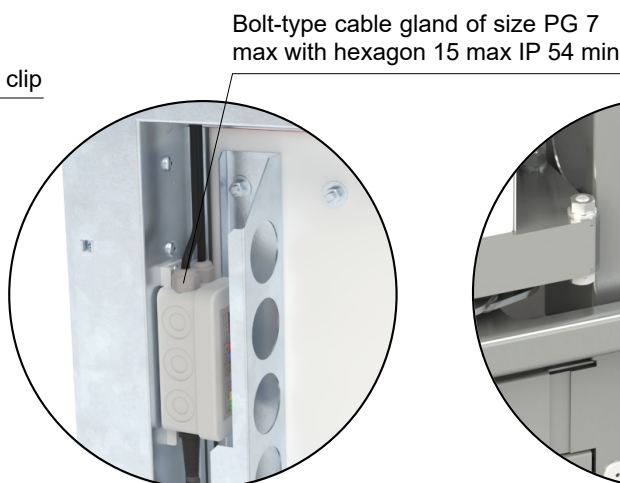
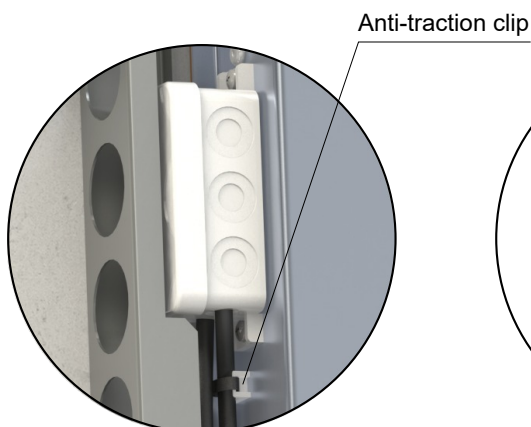
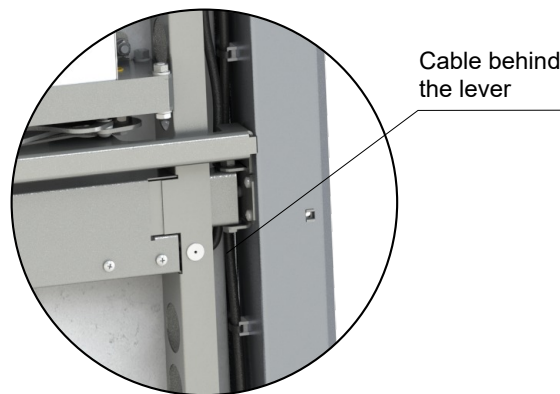
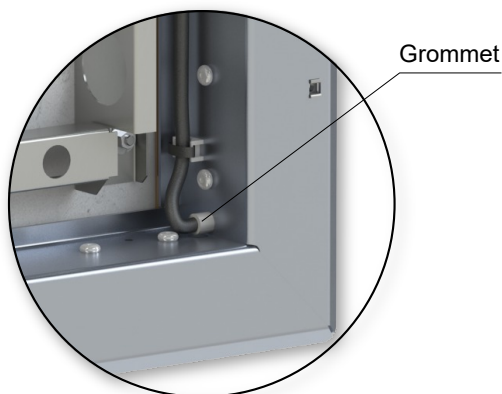

Shock absorber

- Use a shock absorbers (2pcs) that is delivered with the damper (attach it to the shaft wall or damper blades) to prevent damage of SEDM-2D. Height of the shock absorber depends on the distance of the damper from the shaft wall.

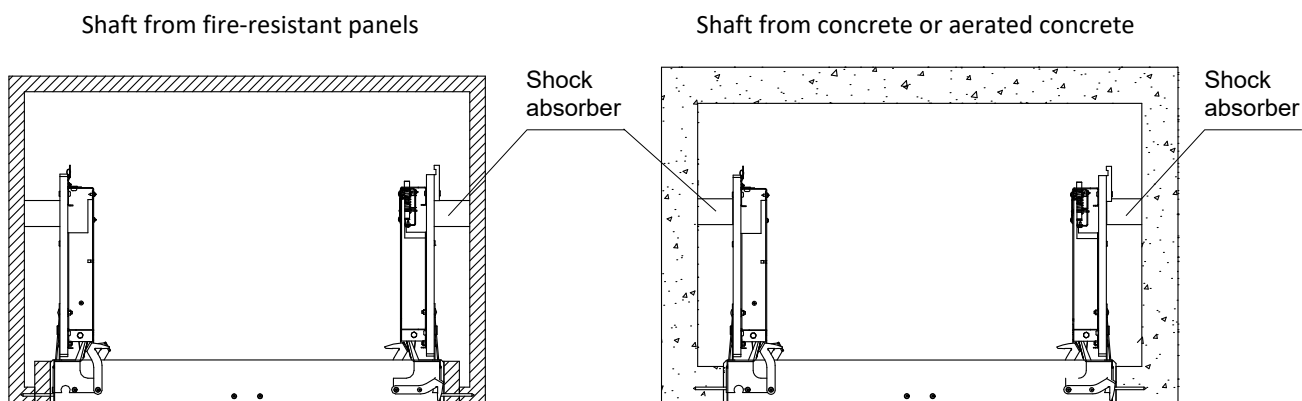

Installation frame

- Installation frame is delivered separately

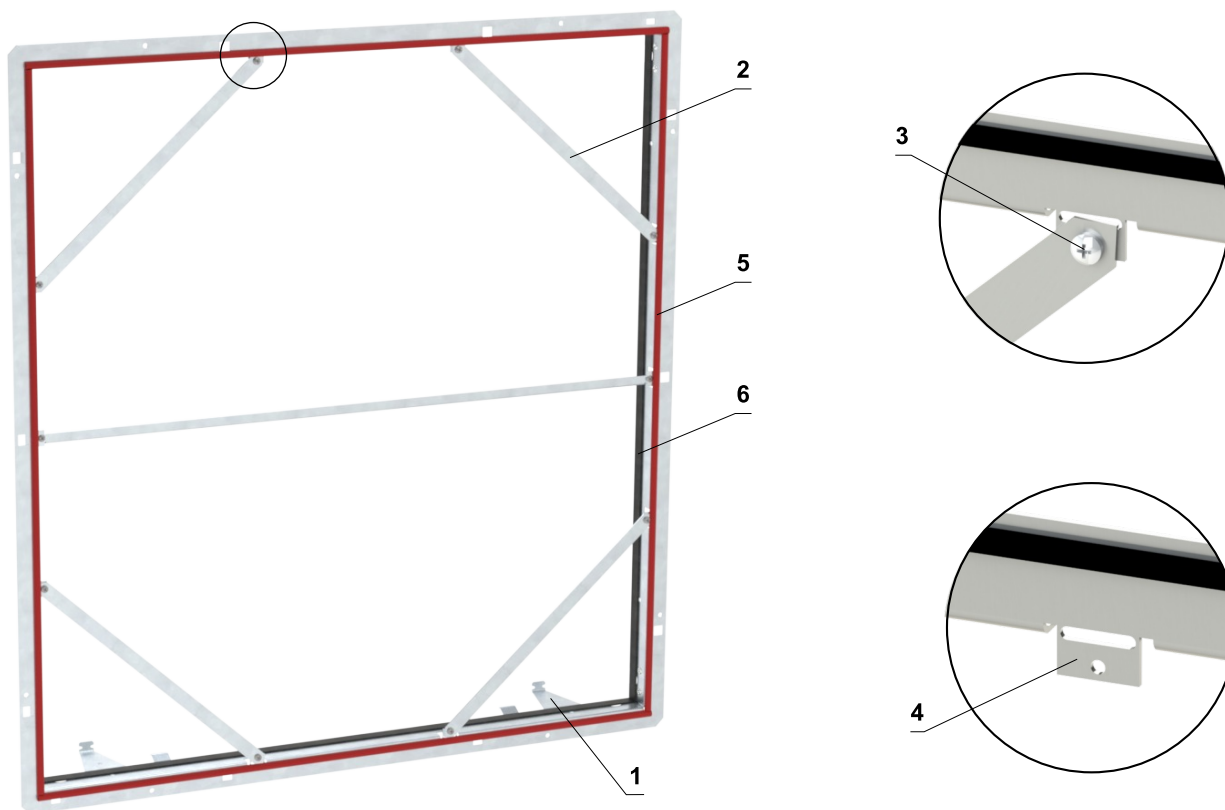

- 1 Fastening plate 4x
- 2 Reinforcement
- 3 Screw for reinforcement
- 4 Mounting plate for reinforcements
- 5 Rubber seal
- 6 Promaseal

Installation procedure

- 1) Prepare an installation opening in dimension $B+20 \times H+20$, for more info → see page 26 and 28
- 2) Prepare an installation frame and apply mastic around the frame at the corners.

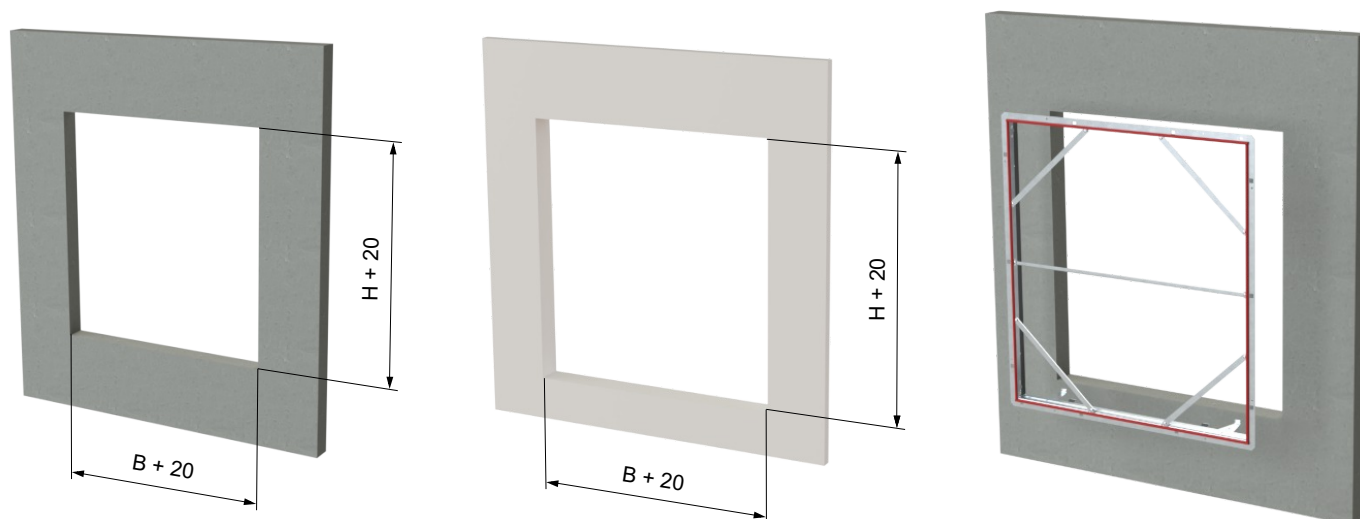

- 3) Install frame into the opening and fix it with screws. Screws 4x30 from the front side of the frame and screws 5x50 from the inner side. Fill the gap between the frame and shaft with mastic. Make sure that the gap is perfectly filled. Let the mastic harden.

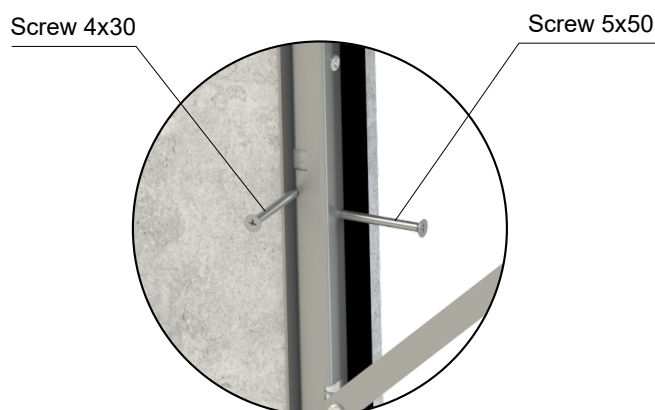
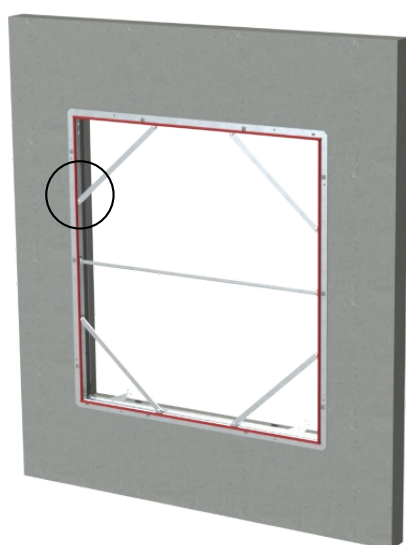

- 4) After hardening the mastic you can remove frame reinforcements by unscrewing the screws and after that, bend or snap mounting plates for frame reinforcements.

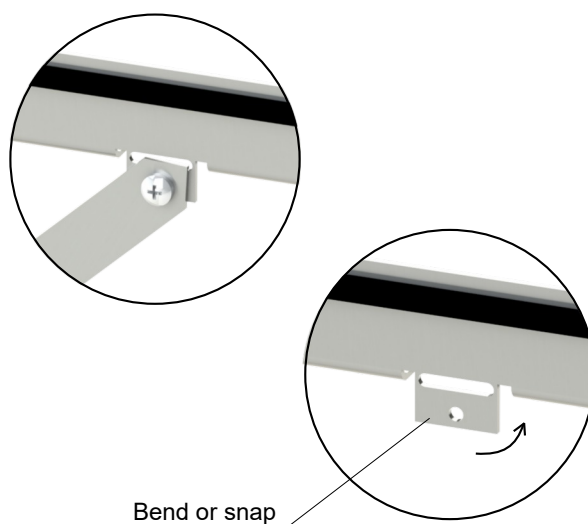
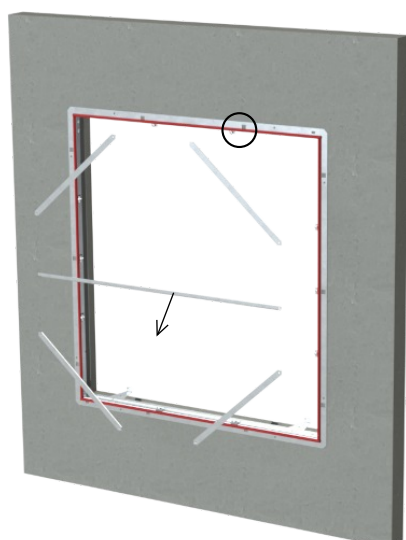

5) Prepare SEDM-2D and set four fastening plates to the "open" position.

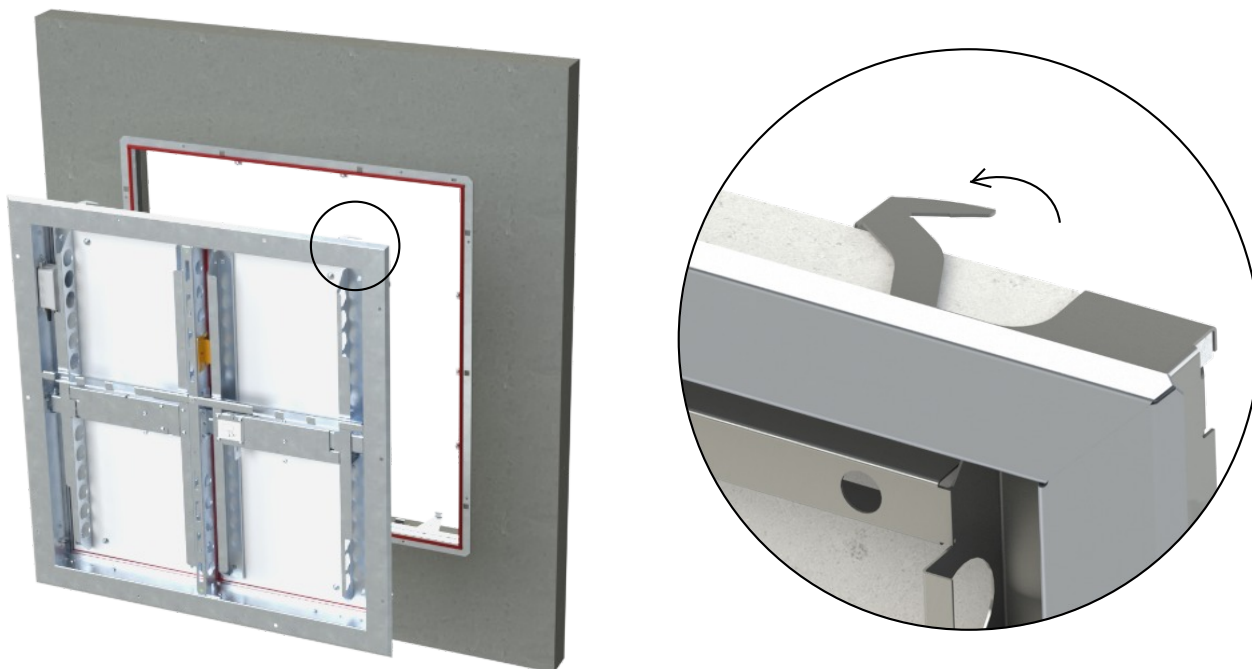

6) Install SEDM-2D on the frame and mount it on four fastening plates.

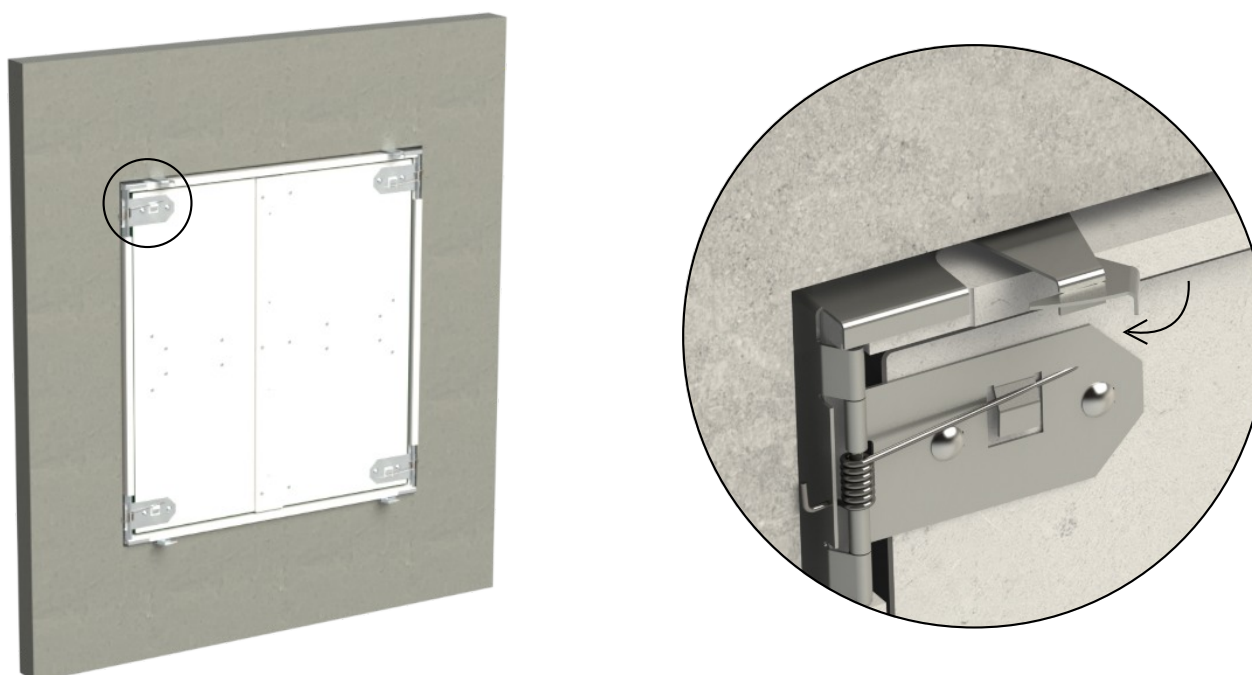

Installation - shaft from concrete or aerated concrete

With mastic

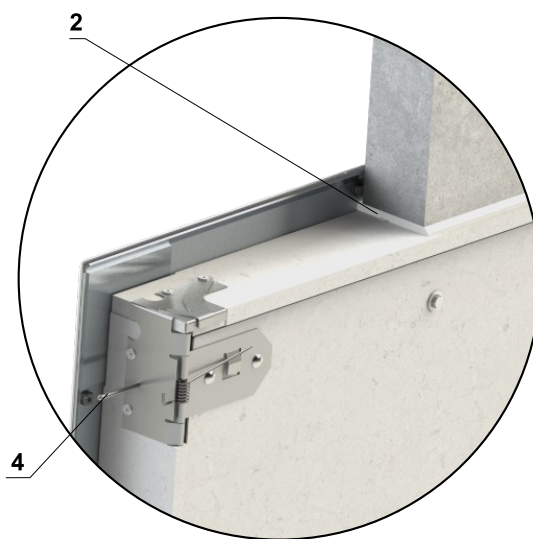

Installation opening

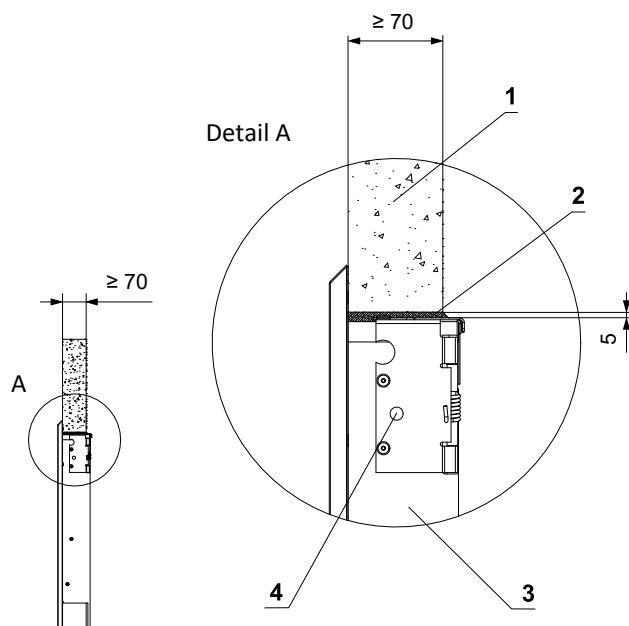
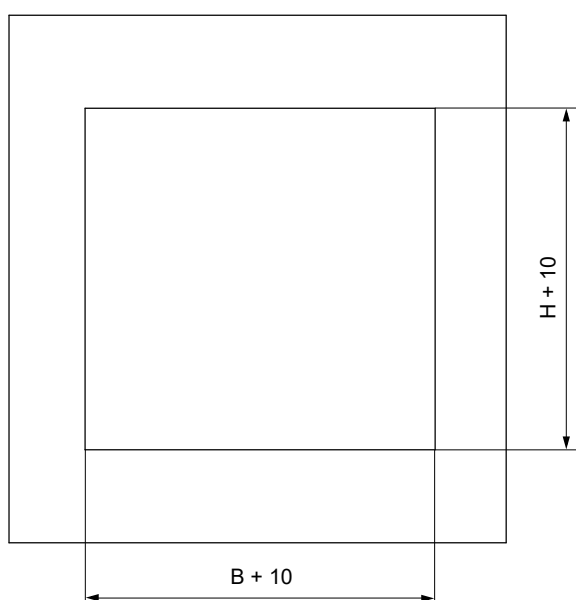

Detail of connection of the damper with shaft

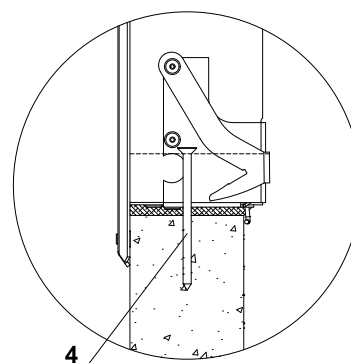

- 1 Concrete or aerated concrete
- 2 Fire-resistant mastic (e.g. HILTI Firestop Acrylic coating SFS-S ACR)
- 3 SEDM-2D
- 4 Screw 6x100 mm 4x (connection of the damper with shaft)

Installation - shaft from concrete or aerated concrete

With installation frame

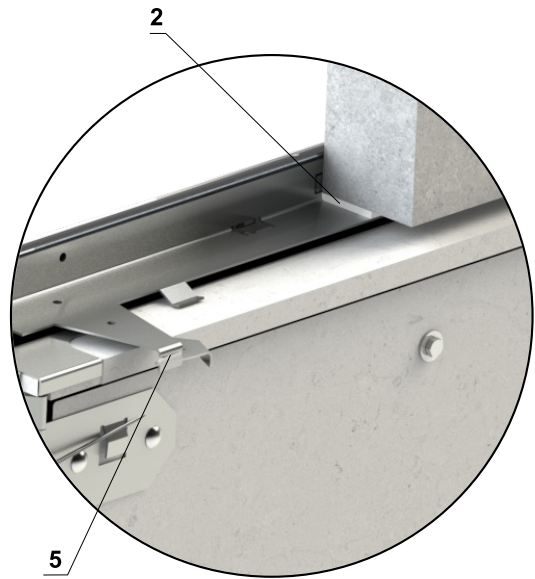
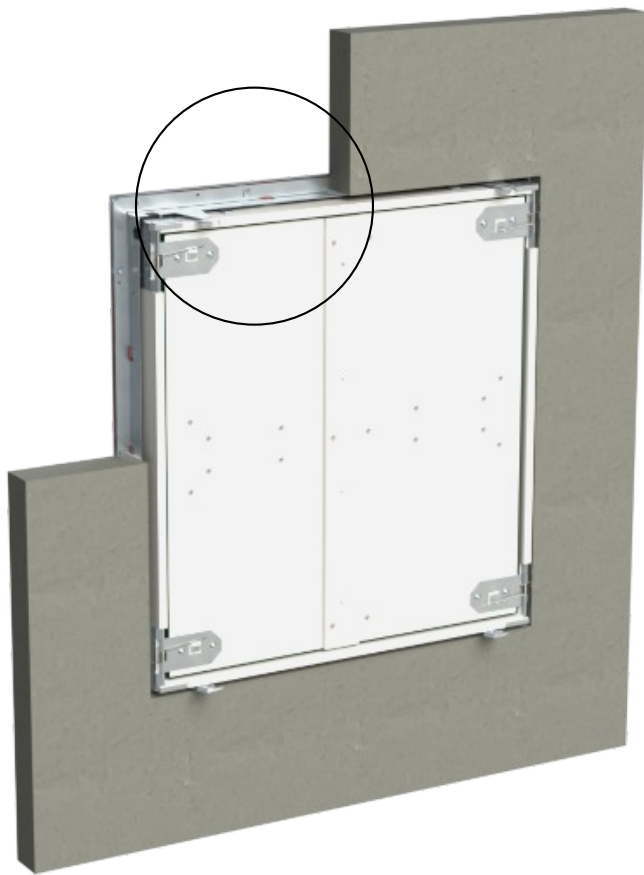

Installation opening

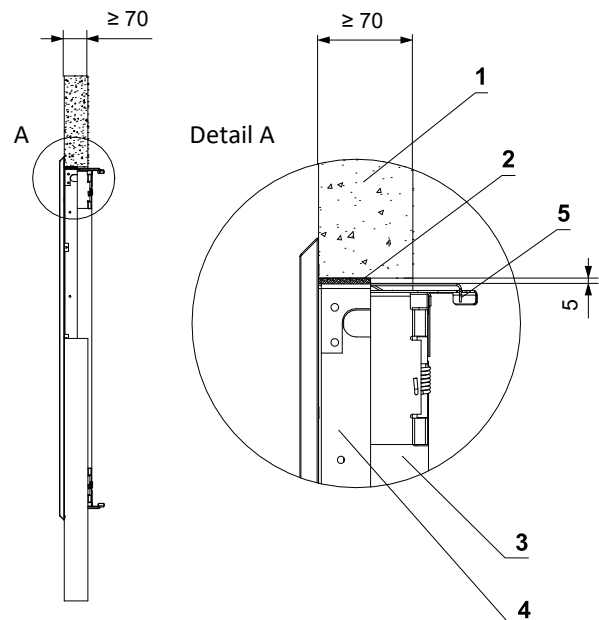
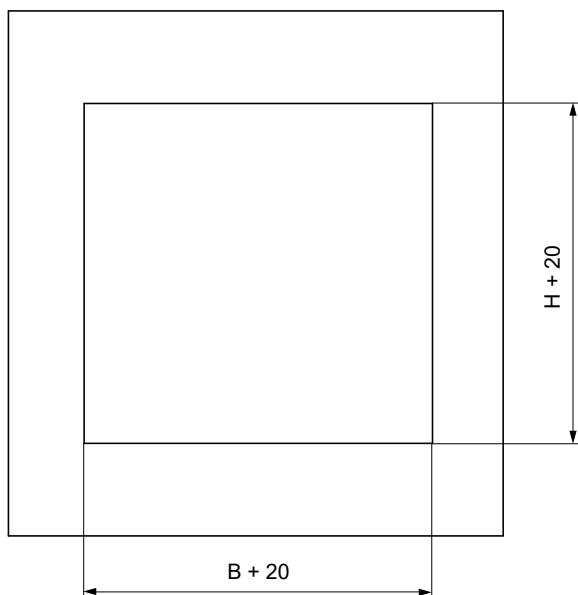

- 1 Concrete or aerated concrete
- 2 Fire-resistant mastic (e.g. HILTI Firestop Acrylic coating SFS-S ACR)
- 3 SEDM-2D
- 4 Installation frame - installation procedure → see page 23
- 5 Installation frame and damper fastening plate 4x

Installation - shaft from fire-resistant panels

With mastic

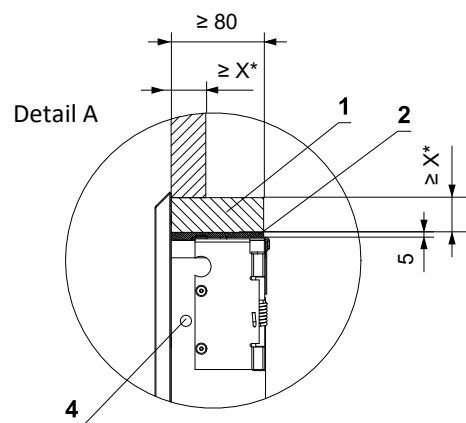
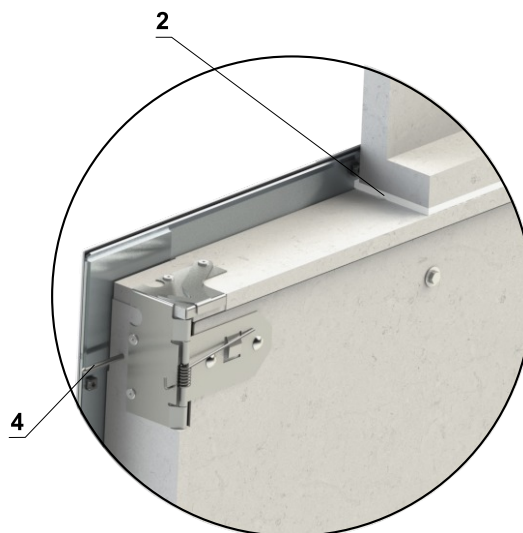

Installation opening

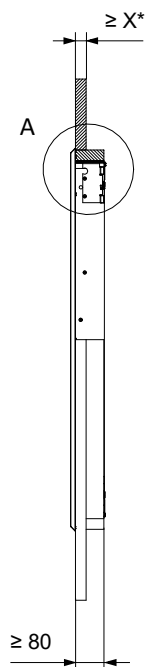
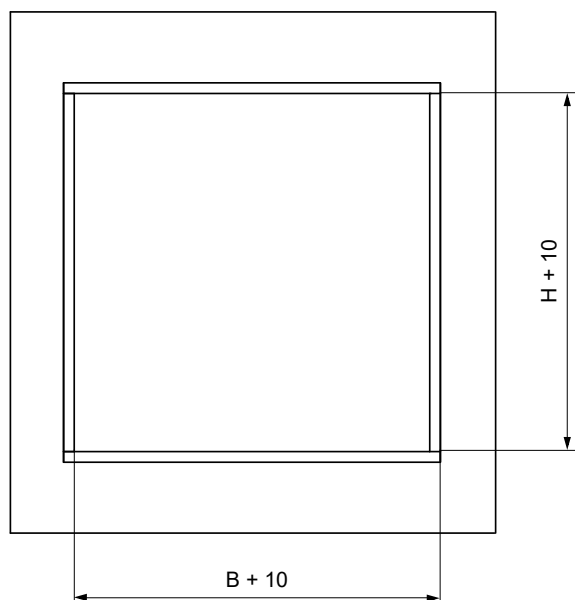

Detail of connection of the damper with shaft

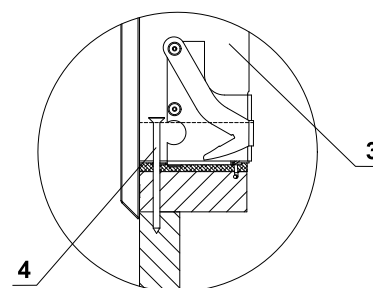

Shaft examples

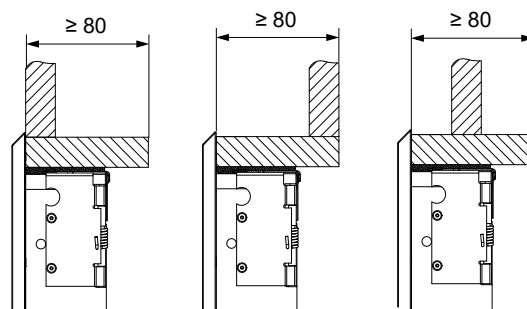

- 1 Fire-resistant panels
- 2 Fire-resistant mastic (e.g. HILTI Firestop Acrylic coating SFS-S ACR)
- 3 SEDM-2D
- 4 Screw 5x70 mm 4x (connection of the damper with shaft)

* X = shaft wall thickness in accordance with the given duct fire resistance class for the given pressure → see page 19

Installation - shaft from fire-resistant panels

With installation frame

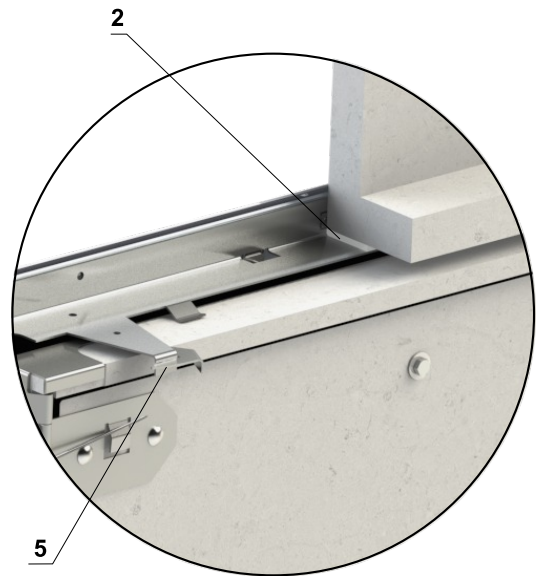

Installation opening

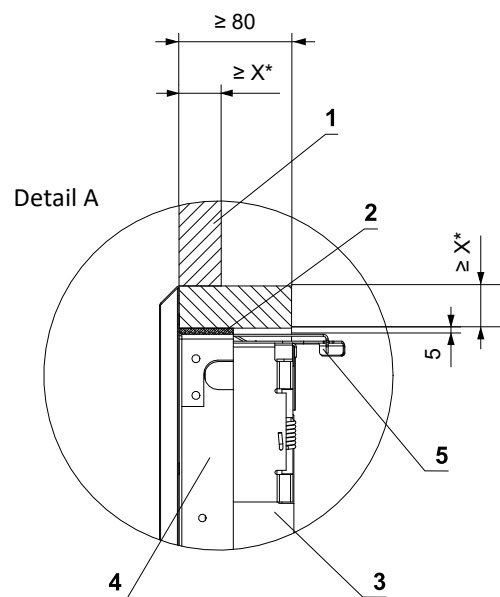
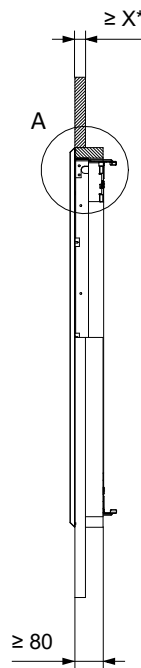
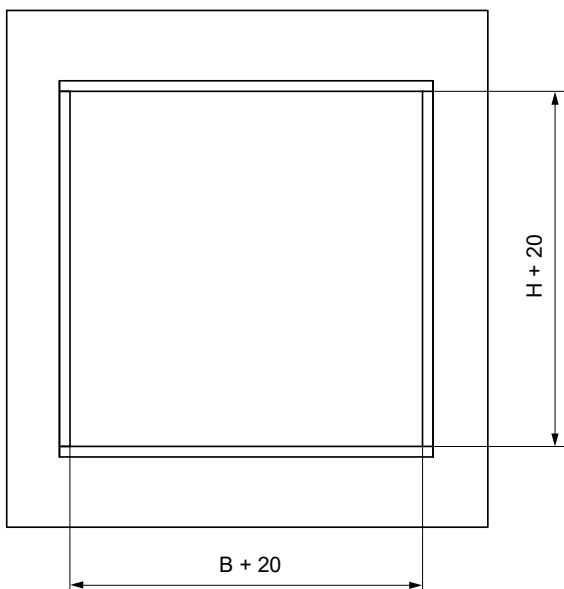

Shaft examples

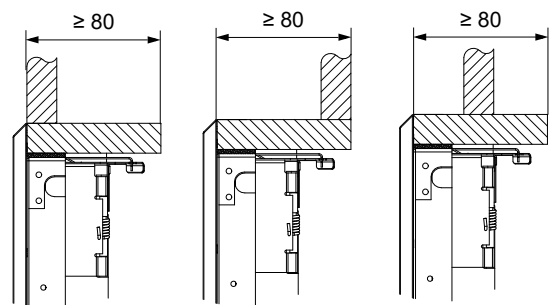

- 1 Fire-resistant panels
- 2 Fire-resistant mastic (e.g. HILTI Firestop Acrylic coating SFS-S ACR)
- 3 SEDM-2D
- 4 Installation frame - installation procedure → see page 23
- 5 Installation frame and damper fastening plate 4x

* X = shaft wall thickness in accordance with the given duct fire resistance class for the given pressure → see page 19

VI. TECHNICAL DATA

Pressure loss

Pressure loss calculation

$$\Delta p = \xi \cdot \rho \cdot \frac{w^2}{2}$$

Δp	[Pa]	pressure loss
w	[m/s]	air flow speed in nominal damper section
ρ	[kg/m ³]	air density
ξ	[-]	coefficient of local pressure loss for the nominal damper section

Coefficient of local pressure loss

H	B															
	350	400	450	500	550	600	650	700	750	800	850	900	950	1000	1050	1105
300	3,125	2,583	2,187	1,888	1,655	1,467	1,314	1,189	1,032	0,911	0,801	0,700	0,606	0,519	0,437	0,360
350	2,824	2,334	1,979	1,709	1,498	1,330	1,191	1,076	0,937	0,828	0,729	0,637	0,553	0,474	0,400	0,331
400	2,554	2,113	1,792	1,547	1,356	1,204	1,079	0,976	0,850	0,752	0,663	0,580	0,504	0,433	0,366	0,304
450	2,309	1,912	1,621	1,400	1,228	1,090	0,977	0,883	0,770	0,681	0,601	0,526	0,457	0,393	0,333	0,277
500	2,086	1,727	1,466	1,266	1,110	0,986	0,884	0,799	0,698	0,618	0,545	0,478	0,416	0,358	0,304	0,253
550	1,884	1,560	1,324	1,144	1,003	0,890	0,799	0,722	0,631	0,559	0,493	0,432	0,376	0,324	0,275	0,229
600	1,736	1,438	1,219	1,054	0,925	0,820	0,736	0,665	0,581	0,515	0,454	0,398	0,346	0,298	0,253	0,211
650	1,564	1,296	1,100	0,951	0,833	0,739	0,663	0,600	0,523	0,463	0,408	0,358	0,312	0,268	0,228	0,189
700	1,412	1,170	0,993	0,858	0,752	0,668	0,599	0,542	0,474	0,420	0,370	0,325	0,283	0,244	0,207	0,173
750	1,278	1,059	0,899	0,776	0,681	0,605	0,542	0,490	0,429	0,380	0,335	0,294	0,256	0,221	0,188	0,156
800	1,162	0,963	0,817	0,706	0,619	0,550	0,493	0,446	0,391	0,347	0,306	0,269	0,234	0,202	0,172	0,144
850	1,064	0,881	0,748	0,646	0,567	0,504	0,452	0,409	0,358	0,318	0,281	0,247	0,215	0,186	0,158	0,132
900	0,982	0,813	0,691	0,598	0,524	0,465	0,418	0,377	0,330	0,292	0,258	0,226	0,197	0,170	0,145	0,121
950	0,917	0,761	0,646	0,559	0,490	0,435	0,390	0,353	0,308	0,273	0,241	0,212	0,184	0,159	0,135	0,113
1000	0,871	0,721	0,613	0,530	0,465	0,413	0,370	0,335	0,293	0,260	0,229	0,201	0,176	0,151	0,129	0,108
1050	0,840	0,696	0,591	0,511	0,448	0,398	0,358	0,323	0,282	0,250	0,220	0,193	0,168	0,145	0,123	0,103
1105	0,826	0,685	0,581	0,503	0,441	0,392	0,351	0,318	0,278	0,247	0,218	0,191	0,167	0,144	0,123	0,103

VII. MATERIAL, FINISHING

- Damper casing and blade are made of fire resistant asbestos-free boards made of mineral fibres.
- Damper frame is made of galvanised sheet metal.
- Damper reinforcements and fasteners are galvanized.
- Installation frame is made of galvanised sheet metal.
- Grille G1 and G3 are made of aluminium sheet metal.
- Grille G2, G5, G6 is made of aluminium alloy.
- Grille G4 is made of steel.
- The colour of grilles will be RAL 9010, with the exception of the grille G1, which will be delivered without paint, unless specified in the ordering key.
- Any other requirements for the design will be considered atypical and will be addressed on an individual basis.

VIII. TRANSPORTATION, STORAGE AND WARRANTY

Logistic terms

- Dampers are **individually packaged** in a special packaging allowing: easy handling and distribution of the dampers on site minimizing the risk of damage and pollution. Stacking of packaged dampers on 120 x 80 cm or 120 x 120 cm palettes, with a possibility to stack dampers of different sizes together; stacking up to 12 layers of dampers on one palette allowed.
- Grilles and installation frames are packed and put on top of the palette with dampers. Note: palette with dampers is non-stackable. Assembly of the palette is then firmly wrapped in a plastic foil; this foil should be removed as soon as possible after the transportation in order to prevent water condensation and resulting degradation of the dampers.
- The dampers must be stored in clean, dry, well-ventilated and dust-free environment out of direct sunlight. Ensure protection against moisture and extreme temperatures (minimum temperature +5°C). The dampers must be protected against mechanical and accidental damage prior to installation.
- Another required packaging system should be approved and agreed by manufacturer. Packaging material is not returnable in case that another packaging system (material) is required and used and it is not included into final price of damper.
- Dampers are transported by box freight vehicles without direct weather impact, there must not occur any shocks and ambient temperature must not exceed +50°C. Dampers must be protected against impact when transported and manipulated. During transportation, the damper blade must be in the "CLOSED" position.
- Dampers must be stored indoor in environment without any aggressive vapours, gases or dust. Indoor temperature must be in the range from -30°C to +50°C and maximum relative humidity 95%.

Warranty

- The manufacturer provides a warranty of 24 months from the date of dispatch for the dampers.
- The warranty for fire dampers SEDM-2D, provided by the manufacturer, is completely void if closing and control devices are unprofessionally handled by untrained workers or if electric components, i.e. end switches, permanent magnets are dismantled.
- The warranty is void if dampers are used for other purposes, devices and working conditions than those allowed by these technical conditions or if the dampers are mechanically damaged during handling.
- If the dampers are damaged by transport, a record must be written down with the forwarder at reception for later complaint.

IX. ASSEMBLY, ATTENDANCE AND MAINTENANCE

- Assembly, maintenance and damper function check can be done only by qualified and trained person, i.e. "AUTHORIZED PERSON" according to the manufacturer documentation. All works done on the fire dampers must be done according international and local norms and laws.
- All effective safety standards and directives must be observed during damper assembly.
- To ensure reliable damper function it is necessary to avoid blocking the actuating mechanism and contact surfaces with collected dust, fiber and sticky materials and solvents.

End switches

- If the damper is equipped with end switches and these switches are not used during operation (e.g. because of a project change), they can be left on the damper and not connected (they need not be dismantled).
- These facts must be recorded in the respective operation documentation of the damper (record books of the damper, fire logs, etc.) and subsequently, adequate function checks must be carried out.

Installation / fixing the damper

- The damper casing shall not be deformed in the course of installation.
- Once the damper is built in, the damper blades shall not grind on the damper casing during opening or closing.

Commissioning and revisions

- Before entering the dampers into operation after assembly and after sequential revisions, checks and functionality tests of all designs including operation of the electrical components must be successfully provided and finished. Check the opening function of the damper blade. After entering into operation, these revisions must be done according to requirement set by national regulations.
- In case that dampers are found unable to serve for their function for any cause, it must be clearly marked. The operator is obliged to ensure that the damper is put into condition in which it is ready for function and meanwhile he is obliged to provide the fire protection by another appropriate way.
- Results of regular checks, imperfections found and all-important facts connected with the damper function must be recorded in the "FIRE BOOK" and immediately reported to the operator.
- It is recommended to provide periodical checks, maintenance and service actions on fire equipment by authorized persons. The authorized persons can be trained by producer, or by authorized distributor. All effective safety standards and directives must be observed during fire damper assembly.
- Visual inspection of proper damper installation, inner area of a damper, damper blade, contact surfaces and silicon seal.

X. ORDERING INFORMATIONS

Ordering key



EXAMPLE:

SEDM-2D EN 700x1105 .24C0H F Q-ZN G3 RAL 9010

Smoke control damper SEDM-2D, dimension 700x1105 mm , hand-operated rearming design with a magnet voltage of 24 V DC without end switches, with installation frame, galvanized material variant, grille design with thin louvers with hidden bolts, color design RAL 9010.

1| Smoke control damper type - SEDM-2D

2| Country of destination

3| Damper dimensions B x H → see pages 15 to 17

"B" is the width of the damper
 "H" is the height of the damper

4| Damper design

.24C0H*	Hand-operated rearming design with a magnet voltage of 24 V DC without end switches
.24C2H	Hand-operated rearming design with a magnet voltage of 24 V DC and with two end switches
.24C4H	Hand-operated rearming design with a magnet voltage of 24 V DC and with two pairs of end switches
.48C0H*	Hand-operated rearming design with a magnet voltage of 48 V DC without end switches
.48C2H	Hand-operated rearming design with a magnet voltage of 48 V DC and with two end switches
.48C4H	Hand-operated rearming design with a magnet voltage of 48 V DC and with two pairs of end switches

* This design is not in accordance with NF 61.937-1, and not in accordance with NF 61.937-10.

5| Installation frame

	Without installation frame
F	With Installation frame

6| Material

Q-ZN	Galvanized
------	------------

7| Grille type

G1	Simple grille with punched profiles
G2	Design grille with aerodynamic profiles
G3	Design grille with thin louvers with hidden bolts
G4	Design grille from drawn steel
G5	Design grille with aerodynamic profiles and with hidden bolts*
G6	Design grille with aerodynamic profiles and with hidden bolts*
GX	Other grilles**

* These grilles are supplied on request from an external supplier. Contact the Mandik sales department.

** Additional third-party review and approval is required. The review process is based on documentation exchange only.

8| Color design of grille

	RAL 9010 *
RAL XXXX	Color shade, acc. to the RAL scale

* Grille G1 is not powder painted as standard. Can be powder painted, if specified in the ordering key.

Grilles G2, G3, G4, G5, G6 are powder painted. If no colour is specified in the ordering key, the colour will be RAL 9010.

Accessories

Grille "Gx"

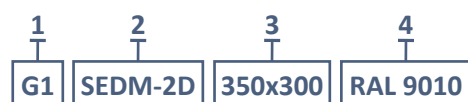

1 | Grille type G1/G2/G3/G4/G5*/G6*/GX**

2 | Smoke control damper type - SEDM-2D

3 | Damper dimensions B x H → see pages 15 to 17

4 | Grille colour RAL - RAL 9010***

* These grilles are supplied on request from an external supplier. Contact the Mandik sales department.

** Additional third-party review and approval is required. The review process is based on documentation exchange only.

*** Grille G1 is not powder painted as standard. Can be powder painted, if specified in the ordering key.

Grilles G2, G3, G4, G5, G6 are powder painted. If no colour is specified in the ordering key, the colour will be RAL 9010.

Installation frame

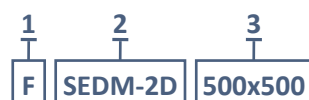

1 | Accessory type - Installation frame F

2 | Smoke control damper type - SEDM-2D

3 | Damper dimensions B x H → see pages 15 to 17

Spare parts

Restraint mechanism



1 | Spare type - Restraint mechanism

2 | Smoke control damper type - SEDM-2D

3 | Voltage 24V/48V

End switch module



1 | Spare type - End switch module

2 | Smoke control damper type - SEDM-2D

3 | Module type

C2	Module with one pair of end switches open-close
C4	module with two pairs of end switches open-close (bipolar)

Data label

- Data label is placed on the damper casing (example)

MANDÍK [®]		MANDÍK, a.s. Dobříšská 550, 267 24 Hostomice, Czech Republic		
MULTI COMPARTMENT SMOKE CONTROL DAMPER - XXXX				
DIMENSION:	<input type="text"/>	DESIGN:	<input type="text"/>	
SERIAL.NO.:	<input type="text"/>	WEIGHT (kg):	<input type="text"/>	
CLASSIFICATION:				MANUAL
TPM XXX/XX	Cert. No.: 1391-CPR-XXXX/XXXX, DoP: PM/XXXX/XX/XX/X	XX	EN 12101:2011	CE 1391

The producer reserves the right for innovations of the product.
For actual product information see www.mandik.com

MANDÍK[®]
www.mandik.com

